

# Thrane IP Handset





# Thrane IP Handset

## User Manual

**Document number:** 98-126059-G

**Release date:** February 24, 2010

## Disclaimer

Any responsibility or liability for loss or damage in connection with the use of this product and the accompanying documentation is disclaimed by Thrane & Thrane. The information in this manual is provided for information purposes only, is subject to change without notice and may contain errors or inaccuracies. Manuals issued by Thrane & Thrane are periodically revised and updated. Anyone relying on this information should acquire the most current version e.g. from <http://www.thrane.com> or from the distributor. Thrane & Thrane is not responsible for the content or accuracy of any translations or reproductions, in whole or in part, of this manual from any other source.

**Copyright** © 2010 Thrane & Thrane A/S. All rights reserved.

## Trademark Acknowledgements:

- **Thrane & Thrane** is a registered trademark of Thrane & Thrane A/S in the European Union and the United States.
- **Inmarsat** is a registered trademark of the International Maritime Satellite Organisation (IMSO) and is licensed by IMSO to Inmarsat Limited and Inmarsat Ventures plc.
- Inmarsat's product names are trademarks or registered trademarks of Inmarsat.
- **Windows** and **Outlook** are registered trademarks of Microsoft Corporation in the United States and other countries.
- Other product and company names mentioned in this manual may be trademarks or trade names of their respective owners.

## Safety Summary

The following general safety precautions must be observed during all phases of operation, service and repair of this equipment. Failure to comply with these precautions or with specific warnings elsewhere in this manual violates safety standards of design, manufacture and intended use of the equipment. Thrane & Thrane A/S assumes no liability for the customer's failure to comply with these requirements.

### **DO NOT OPERATE IN AN EXPLOSIVE ATMOSPHERE**

Do not operate the IP Handset in the presence of flammable gases or fumes. Operation of any electrical equipment in such an environment constitutes a definite safety hazard.

### **KEEP AWAY FROM LIVE CIRCUITS**

Operating personnel must not remove equipment covers. Component replacement and internal adjustment must be made by qualified maintenance personnel. Do not replace components with the cable connected. Always disconnect power and discharge circuits before touching them.

### **DISPOSAL**

Old electrical and electronic equipment marked with this symbol can contain substances hazardous to human beings and the environment. Never dispose these items together with unsorted municipal waste (household waste). In order to protect the environment and ensure the correct recycling of old equipment as well as the re-utilization of individual components, use either public collection or private collection by the local distributor of old electrical and electronic equipment marked with this symbol.



Contact the local distributor for information about what type of return system to use.

---

---

---

# About the Manual

## Intended Readers

This manual is a user manual for the Thrane IP Handset. The readers of the manual include anyone who is using or intends to use the IP Handset. No specific skills are required to operate the IP Handset. However, it is important that you observe all safety requirements listed in the beginning of this manual, and operate the handset according to the guidelines in this manual.

## Manual Overview

This manual has the following chapters:

- **Introduction** contains an overview and a brief description of the IP Handset.
- **Getting started** explains how to connect and start up the handset and gives an overview of the display and keypad. It also contains a short guide to initial configuration and to making the first call.
- **Operating the IP Handset** describes how to use and configure the handset and explains the display menus.
- **Using the web server** explains how to use the built-in web server of the IP Handset.
- **Service & maintenance** contains guidelines for maintenance of the handset, a short troubleshooting guide and gives information on where to get further help if needed.

This manual may not always reflect the latest software functionality of your IP Handset. To obtain the latest version of the manual, please enter the Thrane & Thrane Extranet and download the latest version, or acquire it from your distributor.

---

## Typography

In this manual, typography is used as indicated below:

**Bold** is used for the following purposes:

- To emphasize words.  
Example: “Do **not** touch the antenna”.
- To indicate what the user should select in the user interface.  
Example: “Select **Settings > Display**”.

**Italic** is used to emphasize the paragraph title in cross-references.

Example: “For further information, see *Connecting Cables* on page...”.

**COURIER** is used to indicate display text.

Example: “The display shows **39558880**”.



# Table of Contents

---

	<b>Safety Summary</b> .....	iii
	<b>About the Manual</b> .....	v
<b>Chapter 1</b>	<b>Introduction</b>	
	Welcome .....	1
	Your IP Handset .....	2
	Description .....	2
	The wired IP Handset .....	3
	The wireless IP Handset .....	4
	Features .....	5
<b>Chapter 2</b>	<b>Getting started</b>	
	Getting started with the wired IP Handset .....	7
	Introduction .....	7
	Connectors .....	8
	Connecting the cables to the IP cradle .....	9
	Installing the cradle .....	11
	Connecting the wired IP Handset to a BGAN terminal .....	12
	Starting up the wired IP Handset .....	13
	Getting started with the wireless IP Handset .....	14
	Introduction .....	14
	Preparing the hardware .....	15
	Charging the IP Handset .....	18
	Connecting the IP Handset to your wireless access point .....	20
	Establishing a connection using BGAN terminal .....	21
	Using a BGAN terminal .....	21
	Establishing a connection .....	22
	Connecting subsequent handsets to the BGAN terminal .....	23
	Making the first call .....	25

The IP Handset keypad and display .....26  
The keypad .....26  
The display .....32

**Chapter 3      Operating the IP Handset**

User interfaces .....37  
IP Handset functions .....38  
Handling calls .....38  
Making a call using a BGAN terminal .....46  
Making a secure call from the IP Handset .....47  
Quick settings .....52  
How to enter text in the IP Handset .....54  
Using a headset .....55  
IP Handset menus .....56  
Call log .....57  
Contacts .....59  
Status .....61  
Network .....62  
Settings .....68  
SIP telephony and profiles .....76  
Information from the BGAN terminal .....82

**Chapter 4      Using the web server**

Introduction to the web server .....87  
Browser settings .....87  
Using the web server .....91  
The Home page .....91  
Contacts .....92  
Call log .....93  
SIP settings .....94  
Uploading firmware .....96  
Import and Export settings .....97  
Help and diagnostics report .....99

<b>Chapter 5</b>	<b>Service &amp; maintenance</b>	
	Getting support .....	101
	Maintenance tasks .....	102
	Software update .....	102
	Battery handling for the wireless IP Handset .....	102
	Cleaning the IP Handset .....	103
	Disposal of the IP Handset .....	103
	Troubleshooting guide .....	106
<b>App. A</b>	<b>Technical specifications</b>	
	Thrane IP Handset, wired .....	107
	Specifications, wired handset .....	107
	Outline dimensions, wired handset .....	109
	Thrane IP Handset, wireless .....	111
	Specifications, wireless handset .....	111
	Outline dimensions, wireless handset .....	113
	Thrane IP cradle outline dimensions .....	115
<b>App. B</b>	<b>Conformity</b>	
	Thrane IP Handset, wired .....	117
	CE (LVD & EMC) .....	117
	FCC .....	117
	Thrane IP Handset, wireless .....	119
	CE (R&TTE) .....	119
	FCC .....	119
	FCC/IC Notice .....	121
<b>Glossary</b>	.....	123
<b>Index</b>	.....	127



## *Introduction*

### Welcome

Congratulations on the purchase of your IP Handset!

The IP Handset communicates using Voice over Internet Protocol (VoIP), which means that voice conversations are routed over the Internet or through an IP-based network.

There are two variants of the IP Handset: A wired and a wireless variant.

## Your IP Handset

### Description

The IP Handset is used for making phone calls over an IP based network. When used with a BGAN terminal, the communication is IP based between the handset and the BGAN terminal. From the BGAN terminal, the call is transmitted as a normal circuit-switched call.

You can make secure calls to all IP phones complying with the ZRTP version used by the IP Handset.

The IP Handset has some BGAN terminal control functions. If configured as handset with the local number 0501, you can use the handset to start and stop data connections (background or streaming) for all network user groups.

To improve overall system overview the IP Handset displays active, critical alarms from the BGAN terminal to keep you informed about the status of the BGAN terminal.

The handset is designed specifically for use in harsh environments and it is dust proof and splash proof. Excellent sound quality is achieved by including an efficient noise suppression software. On the large 2.2" color TFT screen, a graphical user interface provides easy access to all functions including contacts and settings. The user interface also provides direct access to certain features of a connected BGAN terminal.

There are two variants of the handset: A wired model and a wireless model.



## The wired IP Handset

The wired handset is powered directly from the LAN interface using Power over Ethernet (PoE), so an external power supply is not needed.

The TT-3670A Thrane IP Handset & Cradle, wired, includes the following main units:

- TT-3672A Thrane IP Handset, wired
- TT-3674A Thrane IP cradle, wired

The IP Handset connects to the cradle with a coil cord. The cradle connects with a fixed LAN cable to a LAN port with PoE, for example in a BGAN terminal (Broadband Global Area Network) for satellite communication.



## The wireless IP Handset

The wireless IP Handset connects to a wireless access point using Wireless Local Area Networking (WLAN).

The internal battery is charged from the dedicated cradle, which connects to an external power supply (10-32 V DC).

Due to the improved power management the wireless IP Handset can be on stand-by time for more than 24 hours.

The TT-3670B Thrane IP Handset & Cradle, wireless, includes the following main units:

- TT-3672B Thrane IP Handset, wireless
- TT-3674B Thrane IP cradle, wireless





## Features

The IP Handset offers the following features:

- Plain voice communication over Internet or IP based network
- Secure voice communication over Internet or IP based network
- Start and stop IP data connections in a connected BGAN terminal
- Contacts list with up to 100 entries
- Intuitive user interface and menu system
- Built-in web interface
- High quality color display QVGA with night colors
- Rugged but elegant design
- Splash proof and dust proof
- Connectivity to Broadband Global Area Network (BGAN) terminal
- BGAN menu to display BGAN terminal type, GPS position and more
- Display of critical alarms of the BGAN terminal



# Getting started

This chapter describes how to install and start up the IP Handset and make the first call. It also gives an overview of the display and keypad and explains how to navigate with the keypad.

## Getting started with the wired IP Handset

### Introduction

The wired IP Handset connects to the cradle with a coil cord. The cradle connects with a fixed LAN cable to a LAN port with PoE, for example in a BGAN terminal. The IP Handset is powered directly from the LAN (PoE) interface.



## Connectors

### *IP Handset connectors*

The IP Handset has a coil cord with a LAN connector for connecting to the cradle or directly to a LAN (PoE) interface.

The handset also has two connectors on the side of the handset:

- one connector for connecting a headset.
- one Mini-USB connector.

**Note**

These two connectors are currently not functional.

### *IP cradle connectors*

The cradle for the IP handset has two internal LAN connectors and an alternative terminal block for the LAN connection:

- One LAN connector connects to the coil cord from the IP Handset.
- The other LAN connector, or alternatively the terminal block, connects to your LAN cable between the cradle and the BGAN terminal.

## Connecting the cables to the IP cradle

To connect the cables to the IP cradle, do as follows:

1. Remove the two screws holding the center cover in the bottom of the cradle and take off the cover.

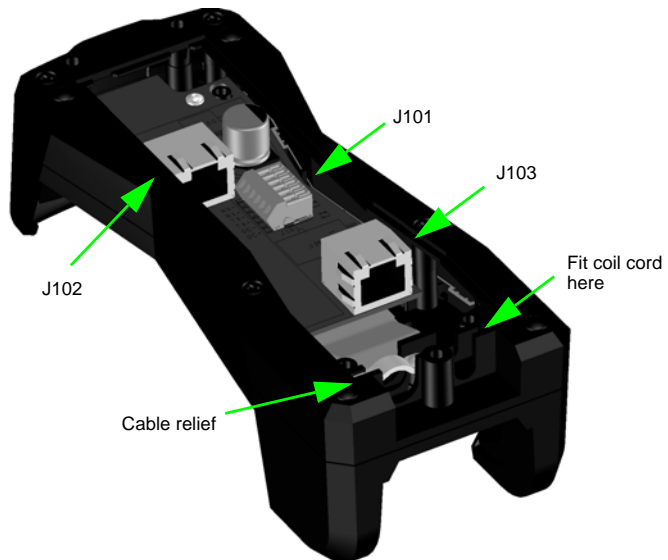

2. Connect the coil cord from the IP Handset to the cradle connector marked J103. Then fit the cable relief mounted on the coil cord into the groove at the cradle exit.
3. To mount the external LAN cable, do one of the following:
  - Connect a standard LAN cable to the connector marked J102 in the cradle. This is the cable for connecting to the BGAN terminal or other LAN (PoE) interface.

### Important

The space between the cable LAN connector and the PCB is very scarce - make sure the housing of the cable connector is not too thick to allow for the connectors to fit properly.

- Connect the wires of a LAN cable to the terminal block marked J101. The text next to the terminal block indicates which signal goes where.
4. Mount cable relief at the cable exit from the cradle.  
**Note** | Make sure the cable relief matches the size of the cable.
  5. Mount the cover and fasten the two screws.

## Installing the cradle

Mount the cradle on a wall or a desktop with 3 screws fitting in the holes indicated in the drawing below (front view).

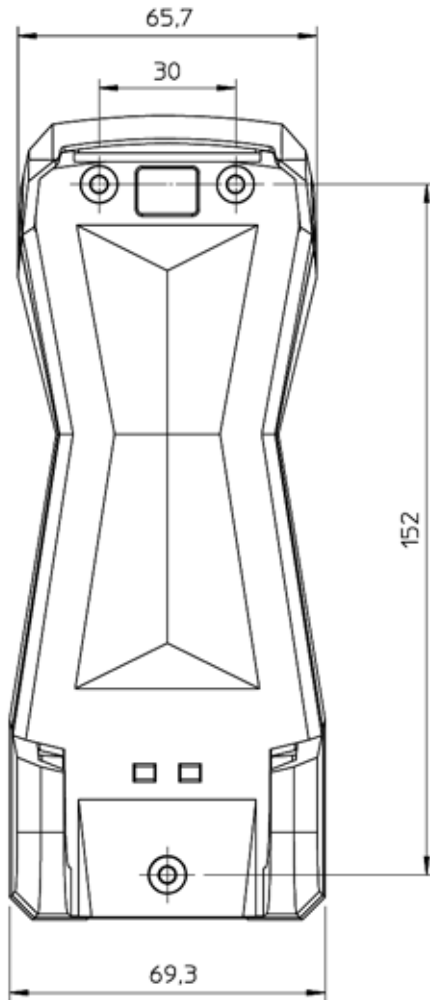

## Connecting the wired IP Handset to a BGAN terminal

**Note**

The LAN interface on the BGAN terminal must supply Power over Ethernet.

To connect the wired IP Handset to a BGAN terminal do as follows:

1. Start up the BGAN terminal as described in the user manual for the terminal.
2. Connect the LAN cable from the IP cradle to one of the LAN (PoE) connectors on the BGAN terminal.

The cable between cradle and terminal must be maximum 80 m.

**Note**

If you insert a switch or similar between the cradle and the terminal, make sure that it conforms to the industry PoE standard **IEEE 802.3 af (using data pairs)**.

The IP Handset starts up automatically when connected to the BGAN terminal. However, you may have to configure user name and password if the handset has not been connected before. For further information, see *Establishing a connection using BGAN terminal* on page 21.



## Starting up the wired IP Handset

### To switch on the IP Handset

The wired IP Handset is automatically powered when it is connected to a LAN interface with PoE.

If the handset has been switched off, you can switch it back on by pressing and holding the on hook key until the display lights up.



If the handset does not start up, the reason may be that there is no PoE in the LAN interface. If you are connecting to a BGAN terminal, check that the PoE indicator on the terminal lights green for the connected port. For further information, refer to the installation manual for the BGAN terminal.

**To switch off** the IP Handset, press and hold the on hook key again until the display is turned off.

# Getting started with the wireless IP Handset

## Introduction

### Overview

The wireless IP Handset connects to a wireless access point, which is connected to a BGAN terminal or other IP connection or directly to a BGAN terminal with integrated wireless access point. The internal battery is charged from the dedicated cradle connected to an external power supply.



## IP Handset connectors

The handset has two connectors on the side of the handset:

- one connector for connecting a headset.
- one Mini-USB 5-pin connector, for charging the handset from a computer or USB charger.

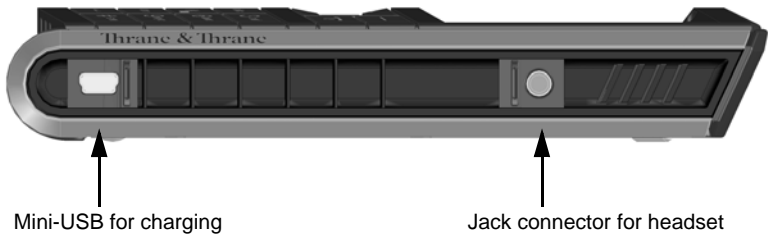

## Preparing the hardware

For the wireless IP Handset you need the following hardware:

- A BGAN terminal with integrated wireless access point or a separate wireless access point complying to the Wireless Local Area Networking (WLAN) standard 802.11b/g
- for charging the handset:
  - an external power supply with 10-32 V DC nominal power, min. 7 W, **or**
  - a computer and a USB cable with a mini-USB 5-pin connector at one end and a USB-A connector at the other end.

### *To connect the wireless access point*

If the BGAN terminal has not an integrated wireless access point you may connect the wireless access point to a BGAN terminal or to your standard network connection.

For information on how to install the wireless access point, refer to the documentation that comes with your wireless access point.

### ***To connect an external power supply to the cradle***

The cradle for the IP Handset serves as a charger when it is connected to an external power supply (10-32 V DC, 7 W).

If you only have access to AC power, a compatible AC-DC power supply, TT-3682L, is available from Thrane & Thrane. This power supply is also used for the EXPLORER 300/500 BGAN terminal.

To connect an external power supply to the cradle, do as follows:

1. On the back of the cradle, unscrew the two screws holding the cover.
2. Remove the cover.

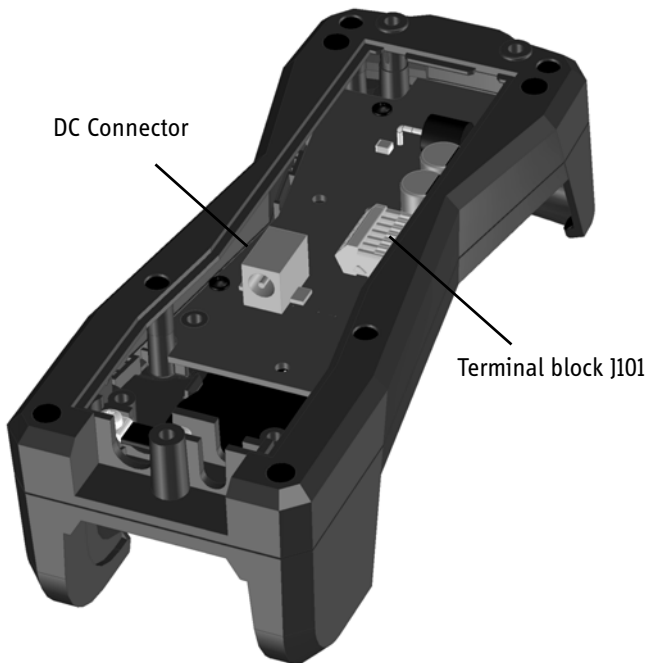

3. Connect your power supply to the cradle.  
There are two options for connecting to the cradle:
  - Using the internal DC connector in the cradle.  
The connector is a proprietary DC Jack, 2.5 mm, positive center.

The connector on the EXPLORER power supply is compatible with this connector.

- Using the internal terminal block (J101).  
Connect the wires from your DC supply to DC+ and DC- in the terminal block J101.

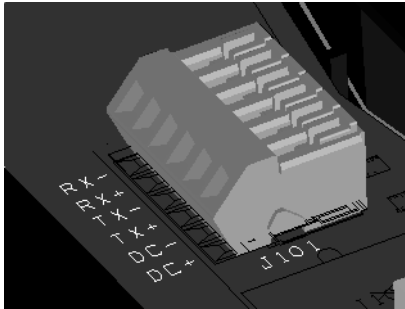

4. Secure the cable with a cable relief at the cable exit on the cradle.

**Note** | Make sure the cable relief matches the size of the cable.

5. Mount the cover and fasten the two screws.

For information on how to mount the cradle on a wall or desktop, see *Installing the cradle* on page 11.

## Charging the IP Handset

### *Introduction*

The battery icon next to the handset icon in the top right corner of the display shows the battery status of the handset. When the battery level is critically low, the handset makes a sound and shows a message, and the icon starts flashing to indicate that the battery needs recharging. If the battery is not recharged, the handset will eventually switch off.



There are two options for charging the handset:

- *To charge the IP Handset using the cradle*
- *To charge the IP Handset from a computer or USB charger (only wireless model)*

On delivery the battery of the IP Handset is approximately 50% charged and ready for use.

### *To charge the IP Handset using the cradle*

The cradle must be connected to an external 10-32 V DC power supply, as described in the previous section.

Place the IP Handset in the cradle with the display facing up. The handset automatically starts the charging process.

### *To charge the IP Handset from a computer or USB charger*

You need a computer or a USB charger and a USB cable with a mini-USB 5-pin connector at one end and a USB-A connector at the other end.

Do as follows:

1. Connect the mini-USB connector to the connector at the side of your handset.

2. Connect the other connector on the cable to a USB port on your computer or your USB charger. The IP Handset automatically starts the charging process.

### *Indications during charging process*

A message appears briefly in the display, the IP Handset makes a sound and the battery icon is animated to show that the battery is charging.

Below are examples of the display when the IP Handset is off and when it is in screensaver mode while charging the battery.

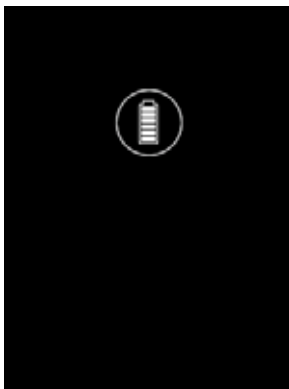
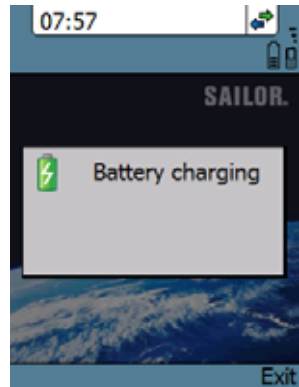

Handset off (animated).  
The icon is turned off after a while, but reappears when a key is pressed.

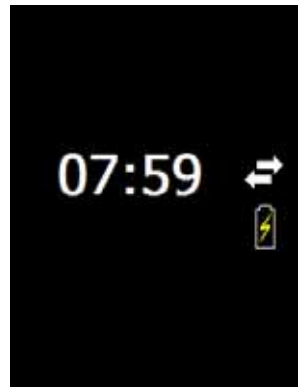

Screensaver mode

**Note**

If the IP Handset is out of use for a longer period of time, recharge the battery every two years to avoid deterioration of the battery.

## Connecting the IP Handset to your wireless access point

**Note**

This procedure is only needed at the first connection. Once connected, the IP Handset automatically attempts to connect to this access point, whether it is integrated in the BGAN terminal or not, whenever it is switched on.

To connect the IP Handset to your wireless access point, do as follows:

1. Start up the wireless access point.
2. Switch on your wireless IP Handset by pressing and holding the on hook key  until the display lights up.
3. Press the center select key to enter the menu system.
4. Select **Network > Wireless network**.
5. When the list of available access points appears in the display, select the access point you want to connect to.

**Note**

Access points with a profile matching your IP Handset are marked with . If this symbol is not present, you cannot connect to an encrypted network until you have set up your wireless profile to match the access point. If you select an encrypted network without a defined profile you are prompted for security settings.

6. If you are prompted for security settings, select **OK** to enter the **Profiles** menu. Set the security settings as described in *To connect the IP Handset to the wireless network* on page 62.
7. Select **Connect**.



The IP Handset now attempts to connect to your wireless access point. If the access point is connected to a BGAN terminal, see *Establishing a connection using BGAN terminal* on page 21.

When the handset is connected to the access point, the display shows **Connected**.

## Establishing a connection using BGAN terminal

### Using a BGAN terminal

#### *Introduction*

By connecting the IP Handset to a BGAN terminal you gain access to the BGAN satellite network with your IP Handset. When the IP Handset is used with the BGAN terminal, it communicates using Internet protocol between the handset and the terminal. However, on the BGAN network side of the terminal the call is transmitted as a circuit switched Standard Voice or 3.1 kHz Audio call.

When connected with the BGAN terminal the IP Handset provides a dedicated menu for the terminal.

#### *IP Handset connection*

**The wired handset** is connected to the BGAN terminal by connecting the Ethernet cable from the cradle to one of the LAN ports of the terminal. For further information, see *Connecting the wired IP Handset to a BGAN terminal* on page 12.

**The wireless handset** is connected to the BGAN terminal either by connecting to the integrated wireless access point of the terminal or a separate wireless access point to one of the LAN ports of the terminal. For information on how to connect the handset to the access point, see *Connecting the IP Handset to your wireless access point* on page 20.

## Establishing a connection

If one or more handsets have already been connected to the terminal, and the new handset has not been connected to the terminal before, you must configure the new IP Handset. You need to set up the user name, password and local number in the IP Handset and in the web interface of the BGAN terminal. For further information, see *Connecting subsequent handsets to the BGAN terminal* on page 23.

### *If no SIM PIN is required*

If the IP Handset is connected to a BGAN terminal where the SIM PIN is disabled or has already been entered, the BGAN terminal automatically sets up a communication profile (SIP profile) and assigns the local number 0501 to the first handset that is connected.

### *If a SIM PIN is required*

If the IP Handset is connected to a BGAN terminal where the SIM PIN is required and has not yet been entered, you need to enter the SIM PIN for the terminal. To do so, you need to know the Administrator user name and password as well as the SIM PIN for the BGAN terminal.

To enter the BGAN terminal's SIM PIN, do as follows:

1. From the main screen of the handset, press the center select key to enter the menu system.
2. Select **BGAN**.
3. Select **Enter PIN code**.

**Note**

This menu item is not available if the PIN has already been accepted. You can check at **Status > PIN status** to see if the PIN has been accepted.

4. Enter the Administrator user name and select **OK**.  
For information on how to type text in the handset, see *How to enter text in the IP Handset* on page 54.

5. Enter the Administrator password and select **OK**.
6. Enter the SIM PIN and select **OK**.

If the SIM PIN is rejected, see the next section *Wrong PIN*.

When the PIN is accepted, the BGAN terminal automatically sets up a SIP profile and assigns the local number 0501 to the first handset that is connected.

### **Wrong PIN**

After entering the user name and password, you have 3 attempts to enter the PIN, before you are asked to enter the PUK (Pin Unblocking Key). The PUK is supplied with your BGAN SIM card.

Enter the PUK followed by a new PIN of your own choice. The PIN must be from 4 to 8 digits long.



#### **Caution!**

If you enter a wrong PUK 10 times, the SIM card will no longer be functional, and you have to contact your Airtime Provider for a new SIM card.

### **IP Handset ready**

When the display shows the handset ready symbol  in the upper right corner, the handset is ready for making a call.

If the handset ready symbol is crossed out  you cannot make a call. The display will normally show a message explaining why the handset is not ready.

## **Connecting subsequent handsets to the BGAN terminal**

If one or more handsets have already been connected to the terminal, you must configure the new IP Handset. You need to set up the user name, password and local number in two places:

- In the IP Handset

- In the web interface of the BGAN terminal.

The first IP Handset is automatically assigned user name 0501 and password 0501. Assign user name 0502 to 0516 and password 0502 to 0516 to further IP Handsets.

### *To set up the user name and password for the IP Handset*

To enter the user name and password in the IP Handset, do as follows:

1. Start up the IP Handset as described in the previous sections.
2. Enter the menu system and select **SIP**.
3. Move to the BGAN profile and select **Options** (left select key).
4. Select **Edit/View**.
5. Select **User name** and enter the user name for your handset. Note that the user name must be the same as the local number for your handset when using the BGAN terminal. Available numbers are 0501 to 0516.
6. Select **Password** and enter the password for your handset. Note this password for later use in the terminal. You can use the local number as the password as well, i.e. 0501 to 0516.
7. Exit the IP Handset menu.

### *To set up the BGAN terminal for additional IP Handsets*

To match the IP Handset with the BGAN terminal you must enter the local number and password for each IP Handset in the web interface of the BGAN terminal.

To set up the BGAN terminal, do as follows:

1. Connect a computer to the LAN interface of the BGAN terminal and start up your browser.
2. Enter the IP address for the terminal. The default IP address is 192.168.0.1. The web interface opens.
3. Select **SETTINGS > IP handsets**.

4. Locate the local number that matches the user name (local number) of your handset and click **New**.
5. Enter the same password you entered in the handset.  
When the terminal and the handset have recognized each other, a **Configure** link appears next to the new handset in the web interface of the terminal. Click the **Configure** link to open the internal web interface of the IP Handset. For information on the IP Handset web interface, see *Using the web server* on page 87.

## Making the first call

To make a call, do as follows:

1. Type the phone number on the keypad.  
If the number is in the Contacts list of the handset, you can also select the number from there and dial up with the off hook key.
2. Press the off hook key in the left side of the keypad  or press #.  
The display shows that the number is being dialled.

If you need to adjust the voice volume during a call and the display shows the main screen, press ▲ or ▼ on the keypad.

For further information on how to make calls, see *Handling calls* on page 38.

For a detailed description how to make secure calls see *Making a secure call from the IP Handset* on page 47.

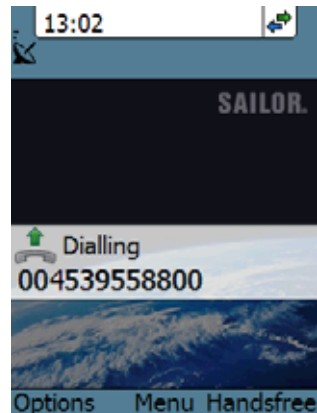

# The IP Handset keypad and display

## The keypad



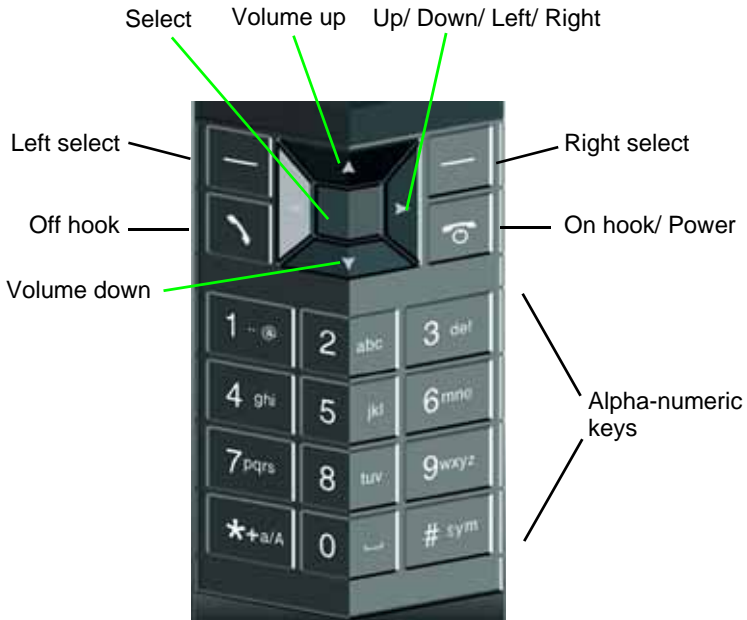

The following drawing shows the keypad of the handset.



The next sections explain the functions of each key in the keypad.

## Control keys

The below table shows the functions of the control keys in the upper section of the keypad.

Key	Functions
	<p>Left select.</p> <p>Selects the function shown in the display just above the key (left soft key).</p>
	<p>Right select.</p> <p>Selects the function shown in the display just above the key (right soft key).</p> <p>From main screen: Opens the Contacts list.</p>
	<p>Off hook.</p> <p>After entering a phone number: Initiates a call to the number.</p> <p>From main screen: Opens a list of the latest calls, including incoming, outgoing and missed calls.</p>
	<p>On hook/ Power.</p> <p>When the handset is ringing: Rejects the call.</p> <p>During a call: Ends the call.</p> <p>When in the menu system: Abandons the menu system and displays the main screen.</p> <p>Otherwise: Powers the handset on/off, when pressed and held for 3 seconds.</p> <p>If there is an error and the handset does not power off after approximately 3 seconds, hold the key for 10 seconds, and the handset will perform a hardware reset.</p>

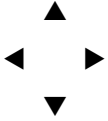
Key	Functions
	<p>Select (center).</p> <p>Selects/confirms the function highlighted in the display.</p>
	<p>Navigation.</p> <p>Navigates through the menu system in the display.</p> <p>Right/Left are also used to change settings in the menus.</p> <p>From main screen: ▲ Volume up, ▼ down</p> <p>See also <i>Keypad shortcuts</i> on page 31.</p>



## Alpha-numeric keys

This section shows the functions of the alpha-numeric keys in the lower section of the keypad.

The functions available depend on whether you are typing a phone number (number mode) or text (text mode).

**In number mode**, you get the number of the key pressed. Only \* has two functions.



Press \* once: The display shows \*.

Press \* twice, or press and hold: The display shows +.

Press #: The display shows #.

See the available functions in text mode on the next page.

**In text mode**, you have the functions listed below.

The \* key switches between text and number mode. There are three options: Numeric, lowercase and uppercase characters. You can see in the lower left corner of the display which mode is currently selected.

To get numbers from lowercase or uppercase mode, press and hold the key.

At numerous presses on the same key, the character changes in the same sequence that the characters are listed in the following table.

Key	Numeric output	Lowercase output	Uppercase output
1	1	. , @ : - ?	. , @ : - ?
2	2	a b c	A B C
3	3	d e f	D E F

Key	Numeric output	Lowercase output	Uppercase output
4	4	g h i	G H I
5	5	j k l	J K L
6	6	m n o	M N O
7	7	p q r s	P Q R S
8	8	t u v	T U V
9	9	w x y z	W X Y Z
0	0	[space]	[space]
*	Switches between lowercase, uppercase and numbers		
#	Symbols. Displays a list with the following additional symbols: . / : @ \$ % ^ & * ( ) ~ ` - _ = + [ ] { } \   ; ´ ¨ ! < > , ? # € <CR>		

### To navigate with the keypad

**To enter the menu system** from the main screen, press the center select key.

**To move through the menus**, press the navigation keys (arrows).





**To select a highlighted menu item**, press the center select key.

**To select one of the items in the action texts area**, press the key just below the text you want to select.

**To go back one level in the current menu**, press the right select key (only when **Back** is displayed above the key).

### Keypad shortcuts

The following shortcuts are available:

	When the display is in the main screen, this key gives direct access to the list of contacts.
	When the display is in the main screen, this key opens a list of the latest incoming, outgoing and missed calls.
	When the display is in the menu system, the on hook key will exit the menu system and show the main screen.
	When the display is in the main screen, the right select key will open the list of contacts.  From inside the Contacts list, press the first letter of an entry to access the entry in the Contacts list.
Alpha-numeric keys	When the display is in the menu system, an alpha-numeric key will jump to the menu item with the pressed number or, in the Contacts list, to the first entry beginning with the pressed letter.

## The display

The color display of the IP Handset is divided into sections with different types of information. The sections are outlined below.

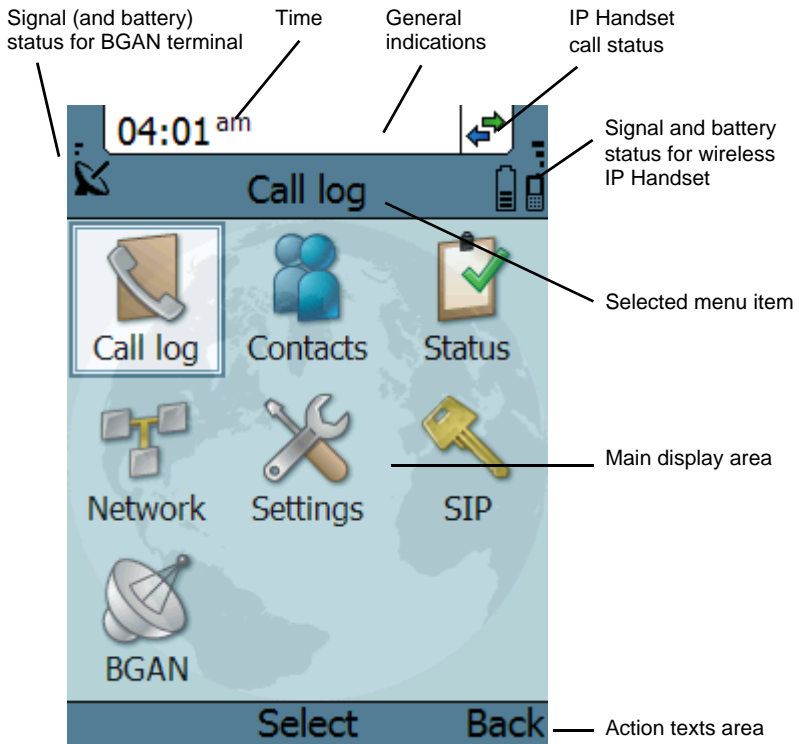

### ***BGAN signal and battery status***

When the IP Handset is connected to a BGAN terminal, the display shows the signal strength of the BGAN signal. If the BGAN terminal is battery powered, the battery status is also displayed.

## ***Time***

The display shows the time of day.

The format is selectable in the **Settings > Date and time** menu.

## ***General indications***

General indications are icons that show dynamic information such as missed calls, sounds off, keypad locked and microphone muted.

For explanations of the icons, see *Icons in the display* on page 34.

## ***IP Handset call status***

This field shows handset status such as whether or not the handset is ready for making calls, or whether there is an ongoing call.

For explanations of the icons, see *Icons in the display* on page 34.

## ***Signal and battery status for wireless IP Handset***

This field shows the signal strength for the wireless connection and battery status for the wireless handset.

## ***Main display area***









The main display area primarily displays the menus and messages to the user.









## ***Action texts area***





The action texts are used to indicate an action that takes place when the corresponding key is pressed. The corresponding key is the key directly below the text (left select, center select or right select).

### Icons in the display

The below table explains the icons in your display.

Icon	Meaning
	Wireless handset (used together with signal strength and battery status).
	BGAN terminal connected (used together with signal strength and battery status if relevant).
	Signal strength for wireless handset and/or for BGAN terminal.
	Battery status for wireless handset and/or for BGAN terminal.
	The handset is ready for making calls.
	The handset is not ready for making calls.
	Active critical alarm in BGAN terminal.
	Incoming call - not yet answered (the handset is ringing).
	Incoming call in progress.

Icon	Meaning
	Outgoing call - not yet answered.
	Outgoing call in progress.
	Call ended.
	Missed call. See the Call log for information on the call.
	The microphone is muted. To reactivate the microphone, select <b>Options (left select key) &gt; Microphone.</b>
	The handset is in silent mode. All external sounds from the handset - including ring tones - are muted. Voice is not muted.
	This symbol is shown when you are adjusting the volume.
	The keypad is locked. To unlock the keypad, press the center select key followed by the left select key.
	This symbol is used in the Contacts list to indicate that the number is from the phone book of the BGAN terminal and is read-only.

Icon	Meaning
	When an alpha-numeric key is pressed from inside the Contacts list, this symbol is shown while the handset is searching for entries with the letter pressed.
	Wait - a task is in progress.
	Shown in the list of wireless access points: The wireless connection is encrypted.
	Shown in the list of wireless access points: The wireless connection is not encrypted.
	Shown in the list of wireless access points: The profile for the wireless access point matches the handset.

### Screensaver

You can choose to have a screensaver activated when the handset is not used for one minute. This screen shows only the time, handset status and general indications such as missed calls.

When you press a key the display returns to the normal display function.

To enable or disable the screensaver, enter the menu system, select **Settings > Display** and select **Screensaver**. When the box is checked, the screensaver is enabled.

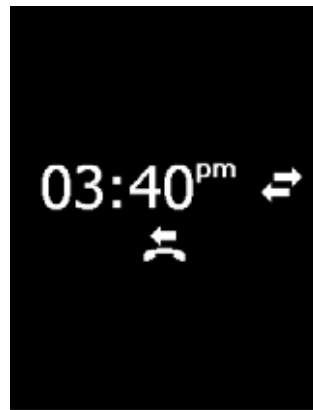



# Operating the IP Handset

This chapter describes how to use the IP Handset. It also describes how to configure the IP Handset and use the display menu system, including a short description of how to use the IP Handset with a BGAN terminal.

For information on how to connect and start up the handset, and how to navigate with the keypad, refer to the previous chapter, *Getting started*.

## User interfaces

The main user interface for the handset is the display menu system. However, with a computer and a browser you can also use the built-in web server to access a subset of the handset settings. This way you can take advantage of a larger screen and still access a subset of the handset settings.

- **The display menu system** is described in *IP Handset menus* on page 56. For an overview of the keys and display, and explanation of keys and display symbols, see *The IP Handset keypad and display* on page 26.
- **The web server** is described in *Using the web server* on page 87.

## IP Handset functions

### Handling calls

#### *Handset ready*

When the status field for the IP Handset shows ready , you can make or receive calls.

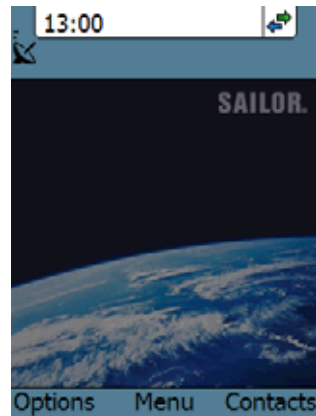

#### *To make a call*

To make a call, simply type the phone number and press  or #.



**Note**

If the handset is in the cradle while you make the call, the mode will automatically be hands-free (default function). For further information, see *To set up the function of the cradle* on page 71.

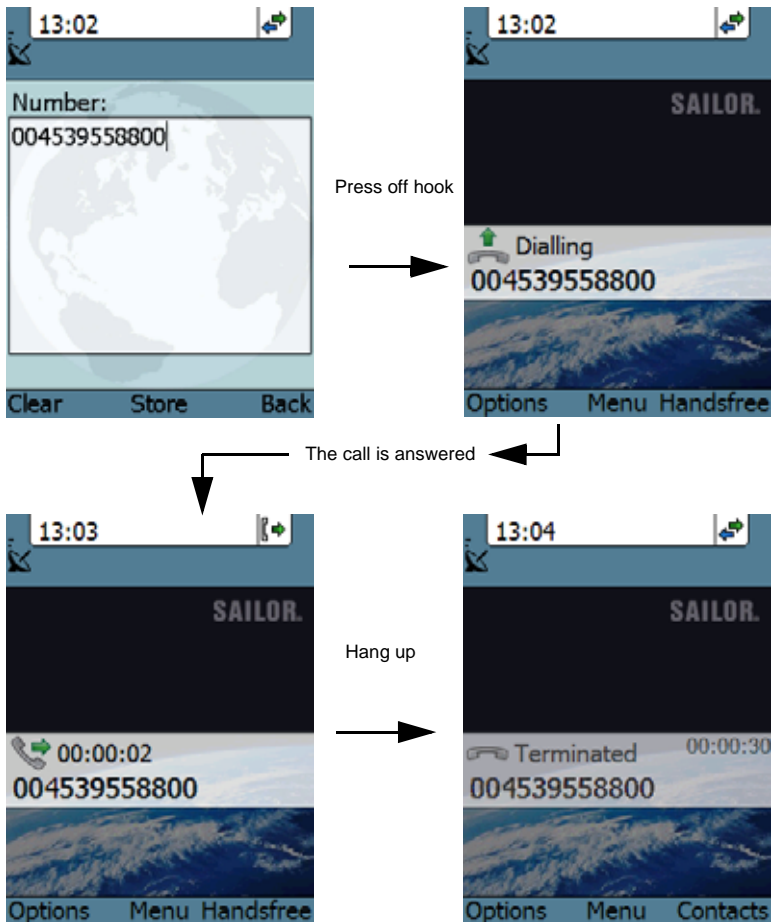
The display shows the progress as follows:



You can also call a number from your contacts or from a list of recent calls:

- **Contacts:** Press the right select key from the main screen and move to the contact you want to call. Then press the off hook key.
- **Recent calls:** To see the latest calls (incoming, outgoing and missed calls), press  from the main screen. Press  again to call the selected number.

For information on how to make calls using a BGAN terminal, see *Making a call using a BGAN terminal* on page 46.

### To receive a call

When the handset is ringing, the display shows the calling name or number, if known.

Answer the call by pressing the off hook key in the left side of the keypad , or by removing the handset from the cradle. For information on cradle detection, see *To set up the function of the cradle* on page 71.

**Note**

If the handset is in the cradle while you answer the call, the mode will automatically be hands-free (by default).

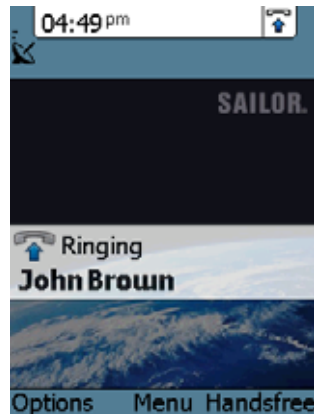

Any open menus are closed down when the handset is ringing.

You can see unanswered calls under **Call log** in the IP Handset menus or in the web interface.

### To transfer a call

When you receive a call, you can transfer it to another phone connected to the terminal. The most commonly used scenario is that you make a blind transfer. This means that you transfer the call directly to a new number, without talking to the new number before putting the call through.

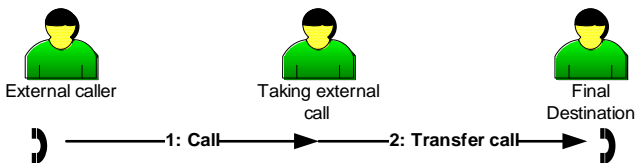

To transfer a call, do as follows:

1. Having taken the call, you press **Options**.
2. Scroll to **Transfer <number to transfer>** and press **Select**.
3. If the local numbers are entered in the phone book, the display shows the local numbers available for transferring the call.  
In the example you can transfer the call to one of the local phones Local 0301 or Local 0503.

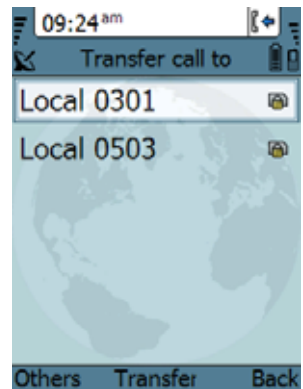
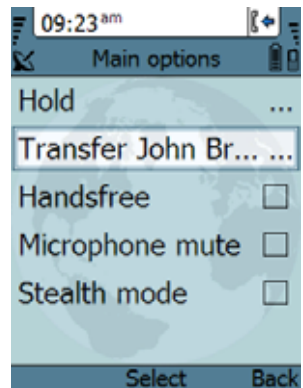
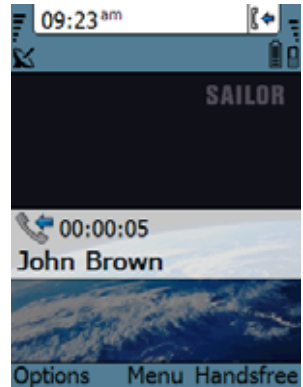

- If there are no entries for local phones in the phone book, select **Enter number** and press **Select**.  
In the example the call is transferred to the local phone 0503.

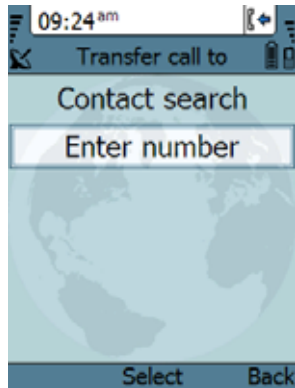

- Enter the local number, in this case **0503**, and press **Transfer**. The BGAN terminal makes sure that the call is transferred properly to the new local number.  
The phone with the local number you dialed starts to ring.

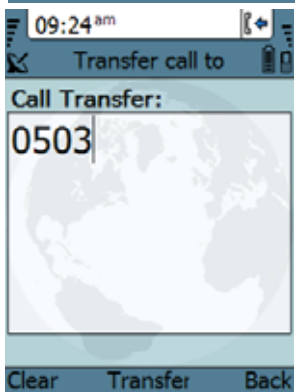

- The incoming call is handed over to 0503. When the call is taken, it is established between the initial caller and the new recipient

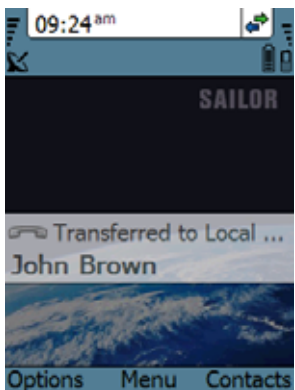

### To transfer a call with announcement

When transferring a call, you can put the current call on hold, call the new number and announce the call to be transferred, terminate the announcement call and then transfer the original call.

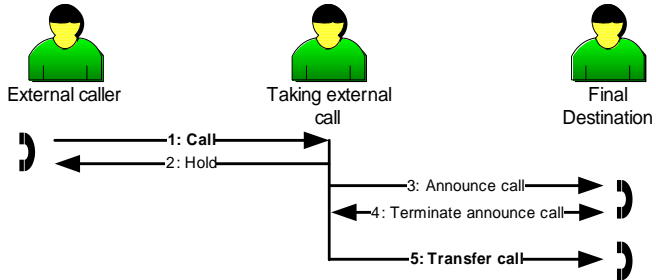

To transfer a call with announcement, do as follows:

1. Having taken the call, you press **Options**.

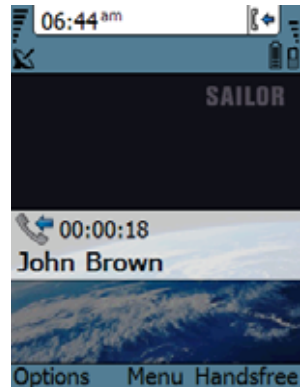

2. Select **Hold** and press **Select**.

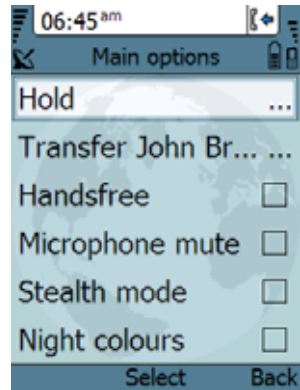

3. The incoming call is put on hold.
4. Select **Enter number** to enter the local number you want to transfer the call to or select **Contact search** to select a number from the **Contacts** list.

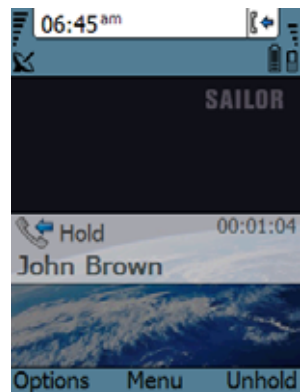

5. In this example the original call is transferred to the local phone 0503. The phone with the local number you dialed starts to ring.

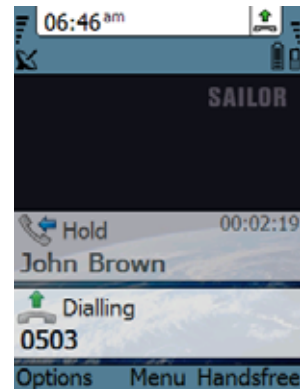





6. When 0503 picks up the call you can announce the original call that is on hold.
  
7. To be able to transfer the original call that is on hold, the announcement call to the local number must be terminated, either by you or the final recipient. This is to free the line for the original call.  
Press the **on-hook key**  to terminate the announcement call, in this example the call to 0503.  
In case you need to talk to the original caller again, press **Switch**.
  
8. If you wish to talk to the original caller again before transferring the call, select **Unhold**.  
Select **Transfer** to transfer the original caller.  
Proceed as described in *To transfer a call on* page 40.

**Note**

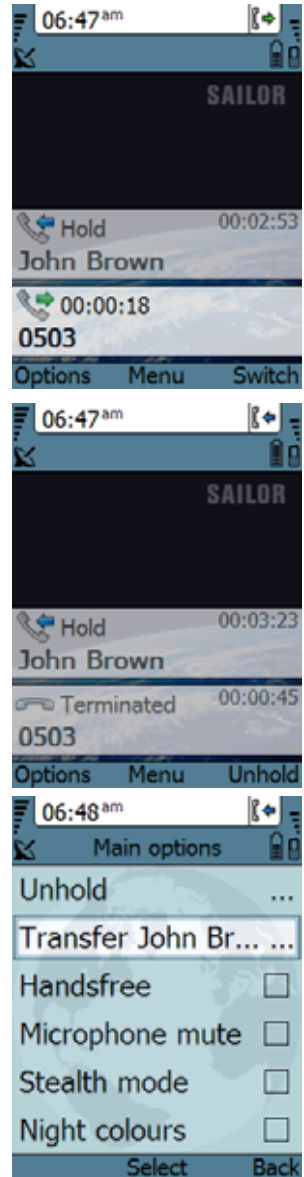
The BGAN system only supports one external call at a time.



### *To end or reject a call*

Press the on hook key  to end an ongoing call or to reject an incoming call.

When the handset is in hand-held mode, you can also end the call by placing the handset in the cradle.

## Making a call using a BGAN terminal

When making a call with the IP Handset using a BGAN terminal you use the BGAN network and its functionality.

### *To make a call from a handset connected to a BGAN terminal*

To make a call from a phone or handset connected to a BGAN terminal, dial

**00 <country code> <phone number>** followed by  or #.

**Example:** To call Thrane & Thrane in Denmark (+45 39558800), dial **00 45 39558800** followed by  or #.

#### Note

The default call type is set up in the web interface of the BGAN terminal. However, you can select the call type for your call, using a prefix.

Dial **1 \*** before the number to make a Standard Voice call.

Dial **2 \*** before the number to make a 3.1 kHz Audio call.

**Example:** Dial **2 \* 004539558800** to make a 3.1 kHz Audio call to Thrane & Thrane in Denmark.

### *To make a call to a handset connected to a BGAN terminal*

#### Note

By default all handsets connected to the terminal will ring on incoming calls.

To make a call to a handset connected to the terminal, dial

**+870 <Mobile number>**

- + is the prefix used in front of the country code for international calls. This is **00** when calling from most countries.
- **Mobile number:** The mobile number of the terminal you are calling.

**Example:** If you are calling from Denmark and the mobile number for 3.1 kHz Audio is 772112345 on your terminal, and you want to make a call to the terminal using 3.1 kHz Audio, dial **00 870 772112345**.

To see the mobile numbers of your terminal, refer to the information included with your airtime subscription.

**Note**

There are two Voice numbers, one for Standard Voice and one for 3.1 kHz Audio.

For more information on call types and the BGAN terminal, refer to the user manual for your BGAN terminal.

## Making a secure call from the IP Handset

The IP Handset supports secure peer-to-peer voice calls. You can make secure calls to all IP phones complying with the ZRTP version used by the IP Handset, see *Technical specifications* on page 107. Standard X.509 certificate has been added for Stronger Authentication (SA) for closed user groups.

### To configure the IP Handset for secure calling

**Note**

**SIP Service Provider details:** In order to make a secure call you must have a SIP account at a SIP Service Provider. You must make sure

- that the Service Provider allows for the ZRTP protocol
- if calling from a BGAN terminal, the Service Provider allows for RTP streaming through the Service Provider's server.

You need your SIP account details to configure the IP Handset. The configuration is the same, whether you use the IP Handset with a BGAN terminal or a router.

To configure a router or a BGAN terminal do as follows:

Unit	Description
Router	Please refer to the manufacturer's documentation.
BGAN terminal	<p>The configuration of the IP connection of the BGAN terminal determines the speech quality of the IP Handset. The following two examples show a high-quality and a best-effort quality.</p> <ul style="list-style-type: none"><li>• Secure connection with <b>guaranteed high speech quality</b>: Start a Streaming data session at 64 kbps. The IP Handset is by default configured to G.711 codec (64 kbit).</li><li>• Secure connection with <b>best-effort speech quality</b>: Start a Standard data session. In this case set the codec priority in the SIP profile of the IP Handset to G.729. For details see <i>To edit a SIP profile</i> on page 80.</li></ul>

To configure the IP Handset do as follows:

1. Make a SIP profile using the SIP account details SIP server, user name and password. For instructions see *To add a new SIP profile* on page 77.
2. Select **SIP** from the main menu, then select the new SIP profile you want to use for communication.
3. Select **Connect**. The handset registers itself, and you are ready to make a secure call.

Typically you make the call and then go into secure mode by selecting **Go secure** in the menu **Main options**. You can go into secure mode anytime during a call. When using the IP Handset in networks where all calls must be secure, you can set the handset to start a secure session automatically each time when a call is initiated and the peer IP Handset goes off-hook. For further details see *To set call services (Noise cancellation and Automatic secure)* on page 70.

### To make a secure call

1. To make a secure call, type the phone number and press  or #.
2. To go secure, the caller or the person called presses **Main options**, then **Go secure** to initiate a secure session. Then the display shows **Going secure**.

The encryption keys are negotiated, the peer is authenticated and the voice streaming is en- and decrypted.

The key negotiation may take up to 30 seconds. During this period, voice is muted.

Upon successful key negotiation and peer authentication, you hear an audio signal in the IP Handset to inform you that a Short Authentication String (SAS) is shown in the display. This string consists of a combination of 4 digits and characters (symbols).

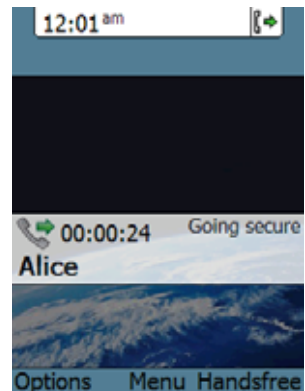
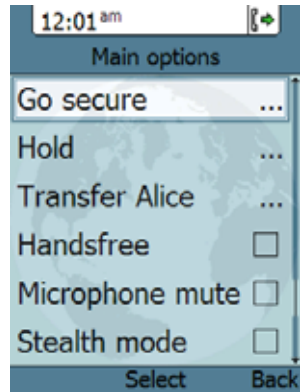

- 3. You must verify the string. Compare your own string with the peer string.

**Example:** Say the first 2 symbols and the peer (i.e. the person called) says the last 2 symbols.

If the comparison of the SAS is ok, press **Yes**.

**Note** If the 4-digit SAS is **not identical**, press **No** when asked to confirm SAS authentication. The secure session is aborted and the call is terminated.

- 4. The line is secure and the display shows **Secure** and a Padlock. Voice streaming is encrypted and decrypted.

**Note** The IP Handset supports one secure call at a time. If there is a secure call established and put on hold, you cannot establish another secure call.

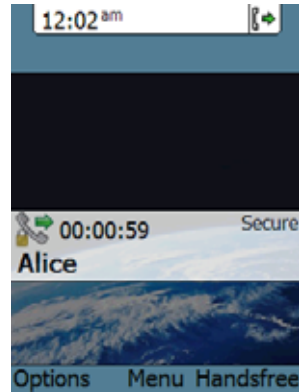
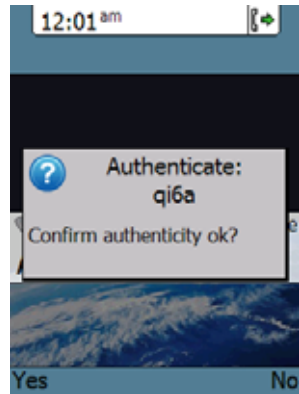

### Failed secure session

A secure session may fail because the negotiation protocol fails or because the verification of authentication certificates fails.

If the negotiation protocol fails, the status window shows a warning. You hear an audio signal in the IP Handset to inform you that the session failed to go secure.

- Press **OK** to continue the call as a non-secure session.

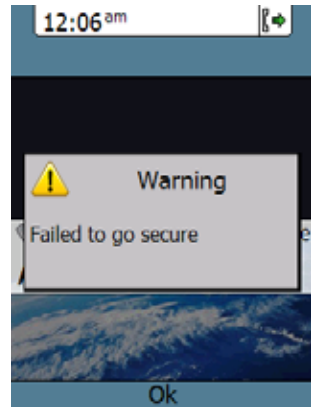

### Failed authentication

If the verification of authentication certificates fails (the peer is not member of the closed user group), the status window shows a warning. You hear an audio signal in the IP Handset to inform you that the peer is not a member of the closed user group.

- Press **Yes** to continue the call as a secure session. Then a 4-digit SAS is shown in the display. Continue as described in step 3 in *To make a secure call* on page 49.
- Press **No** to terminate the call.

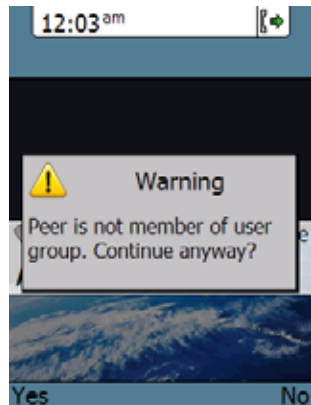

## Quick settings

### *To control the volume in the earpiece*

To adjust the voice volume during a call (with the display in the main screen), press ▲ or ▼ on the keypad.

### *To use hands-free operation*

To enable hands-free operation during a call, use the right select key to select **Handsfree**. To go back to hand-held mode, press the right select key again.

In hands-free mode the sound is routed to a speaker, so that you can use the phone without holding it close to the ear. You can adjust the volume with ▲ or ▼ as described in the previous section.

#### **Handset in cradle:**

You can also make a hands-free call by leaving the handset in the cradle while making the call. Similarly you can answer a call using hands-free mode by leaving the handset in the cradle while answering the call.

In both cases, the default function is as follows:

- If you remove the handset from the cradle during the call, the mode will automatically change to hand-held.
- When the handset is out of the cradle in **hand-held** mode, the call will be terminated when you put the handset back in the cradle.
- When the handset is out of the cradle in **hands-free** mode, you can put it back in the cradle without terminating the call.

#### **Note**

You can change this default function under **Settings > Cradle**, if you want the handset to be independent of the cradle. For further information, see *To set up the function of the cradle* on page 71.



### *To mute the microphone*

You can mute the microphone of the IP Handset. To mute the microphone during a call, do as follows:

1. Select the left **Options** menu.
2. Select **Microphone mute**.

### *To lock the keypad*

You can lock the keypad of the IP Handset. When the keypad is locked you can still answer incoming calls. To lock the keypad, do as follows:

1. Select the left **Options** menu.
2. Select **Lock keypad**.

To unlock the keypad, do as follows:

1. Press the center select key.
2. Press the left select key.

### *To use night mode*

The display has a night mode for operation in low light areas. In night mode, the colors are changed to make the display more suitable for night operation. The IP Handset can be set to automatically switch between day and night mode.

If the automatic switch between day and night mode is not selected, you can activate the night mode manually.

To activate night mode, do as follows:

1. Select the left **Options** menu.

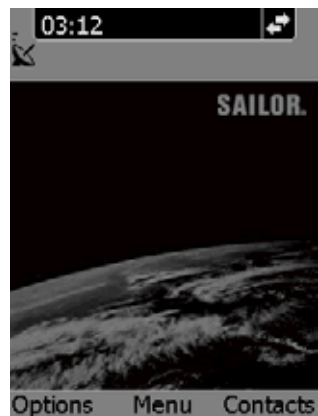

### 2. Select **Night mode**.

To set the IP Handset to automatic switch between day and night mode see *To set up the display* on page 72.

### *To use stealth mode*

Stealth mode is used when the IP Handset should not be noticed. In stealth mode you can turn off all lights in the display and/or sounds for external events. Note, however, that the keypad will still light up when you press a key.

To activate stealth mode, do as follows:

1. Select the left **Options** menu.
2. Select **Stealth mode**.

#### Note

Stealth mode is only activated for the items you have selected in the menu **Settings, Stealth**. See *To set up stealth mode* on page 69.

## How to enter text in the IP Handset

When entering your contacts in the IP Handset you use the keypad to enter the names.

Press \* before the alpha-numeric key to switch between lower case, upper case and numbers.

There are 3 or 4 letters on each key. To obtain the next letter on the key, press the key again.

To move the cursor in the text, use the arrow keys.

To delete the letter just before the cursor, press the left select key **Clear**. Hold the key to delete all the text.

For a list of the key-functions in text-mode, see the table on page 29.

### Example

To type “He”, do as follows:

1. Press \* one or two times until the lower left corner of the display shows upper case letters.
2. Press the key **4 ghi** two times to display the letter **H**.
3. Press \* again until the lower left corner of the display shows lower case letters.
4. Press the key **3 def** two times to display the letter **e**.

### Using a headset

You can connect a headset to the wireless IP Handset as follows:

Plug the headset jack into the jack connector on the side of the handset.

The microphone and speaker of the IP Handset are automatically disabled and the headset is used instead.

## IP Handset menus

The menu system gives you access to the user parameters of the IP Handset. To access the menu system from the main screen, press the center select key. Move around in the menus with the arrow keys and select with the select keys. Leave the menu system by pressing the on hook key.

**Note**

**Wired IP Handset only:** The menus **Wireless network** under Network, **Country** under Network > Settings and **Automatic shut down** under Settings are not present.

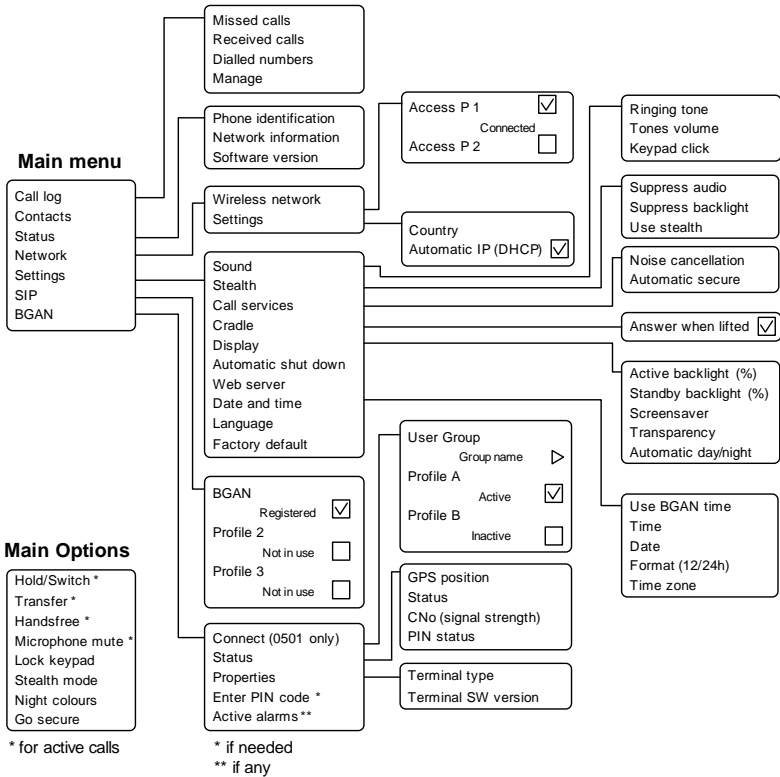

## Call log

The IP Handset logs all calls and dialled numbers. The log entry shows the name (if known), the number, time of the call and duration. Note that the call log can hold maximum 100 calls. You can delete calls from the call log.

### To display the call log

To display the call log do as follows:

1. From the main menu, select **Call log**.
2. Select the list you want to see.
3. If you want to see details for a call, move to the call and select **View**.

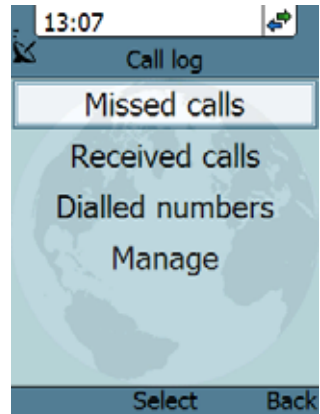

### To add a number from the call log to the Contacts

To add a number from the call log to the Contacts do as follows:

1. In the call log, go to the call and select **Options**.
2. Select **Add to contacts**.  
Note that the Contacts list can hold maximum 100 entries.
3. Type in the name of your new contact and select **OK**.

### *To delete a number from the call log*

To delete a number from the call log do as follows:

1. In the call log, go to the call and select **Options**.
2. Select **Delete**.
3. Select **Yes**.

### *To delete all numbers in a call log folder*

To delete all numbers in the call log, or all numbers in a sub-folder of the call log, do as follows:

1. In the call log menu (not in one of the sub-folders) select **Manage**.
2. Select the folder you want to empty.
3. Select **Yes**.

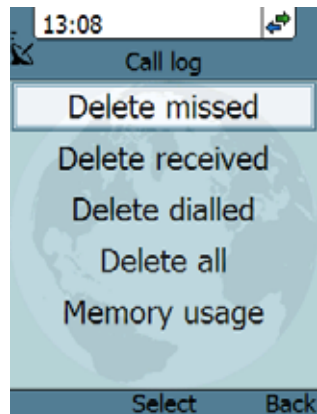

### *To see memory usage in the call log*

To see the number of stored entries and the maximum allowed number of entries, do as follows:

1. In the call log menu (not in one of the subfolders) select **Manage**.
2. Select **Memory usage**.

## Contacts

Use the contact list of the IP Handset to find a contact and make a call or manage your contacts. You have access to the contacts in the BGAN phone book.

### To display your contacts

To display your contacts, do one of the following:

- From the main screen, press the right select key,
- from the main screen, press ▼, or
- from the main menu, select **Contacts**.

If a contact is from the BGAN phone book it is marked with . This means you cannot edit or delete the entry.

### To call a contact

To call a contact, do as follows:

1. In your Contacts list, scroll to the contact you want to call.
2. Press the off hook key.

### To add a contact

To add a contact, do as follows:

1. In your Contacts list, press the left select key, **Options**.
2. Select **Add**.

Note that the Contacts list can hold maximum 100 entries.

3. Type in the name of your contact and select **OK**.

The name can be maximum 32 characters.

For information on how to enter text, see *How to enter text in the IP Handset* on page 54.

4. Scroll to **Number** and select **Edit**.
5. Type in the number of your contact and select **OK**.  
The number can be maximum 32 characters.

### *To edit a contact*

To edit a contact, do as follows:

1. In your Contacts list, scroll to the contact you want to edit.
2. Press the left select key, **Options**.
3. Select **View/Edit**.
4. Select **Edit**.
5. Change the name of your contact and select **OK**.  
For information on how to enter text, see *How to enter text in the IP Handset* on page 54.
6. Scroll to **Number** and select **Edit**.
7. Change the number of your contact and select **OK**.

### *To delete a contact*

To delete a contact, do as follows:

1. In your Contacts list, scroll to the contact you want to delete.
2. Press the left select key, **Options**.
3. Select **Delete**.
4. Press the left select key, **Yes**.

The contact is now deleted from your Contacts list.



## Status

In the Status section you find the serial number of the IP Handset and the network settings. Use this menu to display the software version of the IP Handset.

To view status for the handset, do as follows:

1. From the main menu, select **Status**.
2. Select **Phone identification** to see the serial number of the IP Handset.
3. Select **Network information** to see:
  - DHCP Enabled/Disabled
  - IP address
  - Subnet mask address
  - Default gateway
  - Physical address (MAC)
4. Select **Software version** to see the version of the IP Handset software.

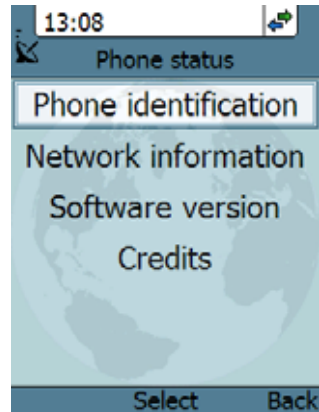

## Network

**Note**

The Wireless network menu described in the following sections is only available in the wireless handset. For the wired handset, go to *To select the IP address mode* on page 67.

### To connect the IP Handset to the wireless network



If your handset has been connected to the wireless access point before, it will automatically attempt to establish a connection as soon as the access point is within reach.

If it is the first time you connect the IP Handset to the wireless access point, you need to manually connect to the access point.

To connect the IP Handset to the access point, do as follows:

1. Start up your wireless access point.
2. Start up the IP Handset.
3. Enter the menu system and select **Network > Wireless network**.

A list appears with all wireless access points within reach, together with previously connected access points.

-  : the handset already has a profile for this access point.
-  : the access point uses encryption.
-  : the access point does not use encryption.

The connected access point (if any) is always placed at the top.



4. Select **Connect** at the network you want to connect to.

If your access point does not use encryption, the handset will automatically connect and create a new profile for the access point.

5. If your access point uses encryption and it is the first time you connect, you are prompted for security settings, select **OK** to enter the **Profiles** menu. Set the security settings as described in *To connect the IP Handset to the wireless network* on page 62.



When the profile matches the access point, and you have selected **Connect**, the IP Handset attempts to establish a connection. If the access point is connected to a BGAN terminal, see *Using a BGAN terminal* on page 21 for information on how to connect to the BGAN network.

When the IP Handset is ready for use, you see the handset ready symbol  in the top right corner of the display.

Normally a new profile is automatically created when you connect to an access point.

### To edit a Wireless network profile

To edit a Wireless network profile, do as follows:

1. From the main menu, select **Network > Wireless network**.
2. Select the access point you want to change profile for.
3. Press the left select key, **Options**.  
Note that if no profile is defined for the selected access point, this menu will only show Connect and Manage.

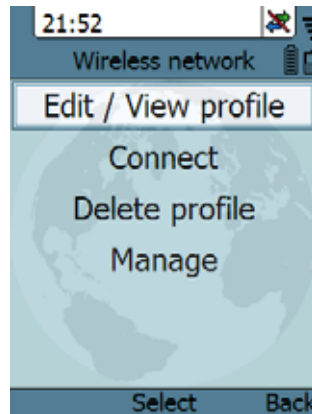

4. Select **Edit/View profile**.  
The SSID (name of the Wireless network) and security mode of the selected access point are automatically detected by the handset.  
For security mode WEP set the following (see also the documentation for Wireless Access Point):

- Authentication: Select Open system or Shared key
- Encryption level: Select 64-bit or 128-bit
- WEP key index: Select 1, 2, 3 or 4.
- Use hexadecimal key: Select whether you want to enter the encryption key in hexadecimal numbers or text.
- WEP key: Enter WLAN encryption key.

For security mode WPA-PSK-TKIP or WPA2-PSK-AES set the following (see documentation for Wireless Access Point):

- Use hexadecimal key: Select whether you want to enter the encryption key in hexadecimal numbers or text.
- Encryption key: Enter WLAN encryption key.

5. Select one of the following:
  - **Connect** (left key) if you want to connect immediately to the access point, or
  - **Back** (right key) if you want to save the profile for later.

### To delete a Wireless network profile

To delete a Wireless network profile, do as follows:

1. In the Wireless network list, go to the access point for which you want to delete the profile.
2. Select **Options** (left select).
3. Select **Delete profile**.
4. Select **Yes** (left select).

The profile for the selected access point is now deleted. If the access point uses encryption, your handset will not be able to connect to the access point unless the security settings are entered again.

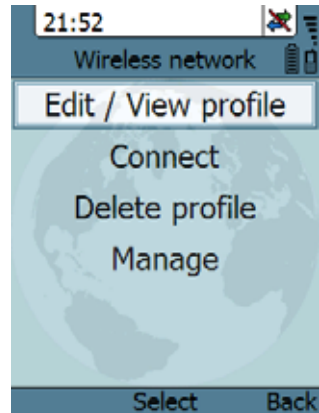

### To delete all Wireless network profiles

To delete all Wireless network profiles, do as follows:

1. From the Wireless network list, select **Options** (left select).
2. Select **Manage**.
3. Select **Delete all profiles**.

#### Important

When you delete all profiles you will not be able to connect to any access point using encryption, unless you enter the security settings again!

4. Select **Yes** (left select) to confirm.



### *To create a new Wireless network profile*

Normally a new profile is automatically created when you connect to an access point. If needed, you can define a profile for an access point that is not currently within reach.

To create a new Wireless network profile, do as follows:

1. From the Wireless network list, select **Options** (left select).
2. Select **Manage**.
3. Select **Add profile**.
4. Type in the SSID of the access point.
5. Select **OK**.

A new profile is now created

6. Enter the security information for the access point. For further information, see *To edit a Wireless network profile* on page 64.



### *To see memory usage in the list of Wireless network profiles*

To see the number of stored profiles and the maximum allowed number of profiles, do as follows:

1. From the Wireless network list, select **Options** (left select).
2. Select **Manage**.
3. Select **Memory usage**.



### To set the country for Wireless network use

To make sure you have the right settings for the country your IP Handset is currently located in, you have to enter the country in the handset.

#### Important

In some countries, the use of Wireless networks (WLAN) is not allowed. Before continuing, make sure WLAN is allowed and licensed in the country where you intend to use it.

To enter the country, do as follows:

1. Select **Network > Settings > Country**.
2. Scroll to the country your handset is located in and select it.  
If the country is not in the list, select **Other**.

### To select the IP address mode

You can select whether or not the IP Handset should use DHCP to automatically obtain an IP address. Static IP addresses are also supported. It is recommended to use DHCP. Automatic IP (DHCP) is the default setting.

To select the IP mode, do as follows:

1. From the main menu, select **Network**.
2. Select **Settings**.
3. Do one of the following:
  - If the IP Handset should use DHCP to automatically obtain an IP address, check the box next to **Automatic IP (DHCP)** and select **Back** or press the on hook key to exit completely.
  - For a static IP address, clear the box next to **Automatic IP (DHCP)**. Then select **Yes** to confirm and continue to the next step.

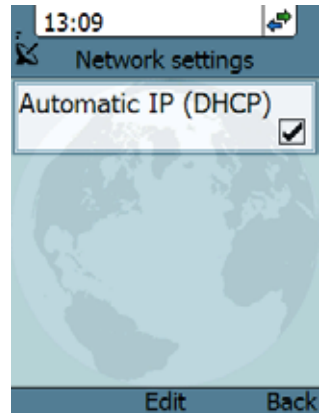

4. If you selected not to use DHCP, scroll down to **IP address**.
5. Click **Edit**, type in the IP address and select **OK**.
6. Continue to **Subnet mask**, **Gateway**, **Primary DNS** and **Secondary DNS** and enter them in the same way.
7. Select **Back** or press on hook to exit.  
The handset will now use the static information you entered, instead of automatic IP address allocation using DHCP.

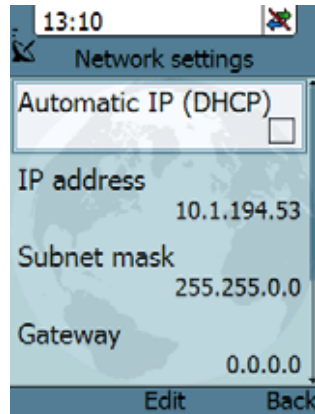

## Settings

To access the Settings menu, select **Settings** from the main menu.

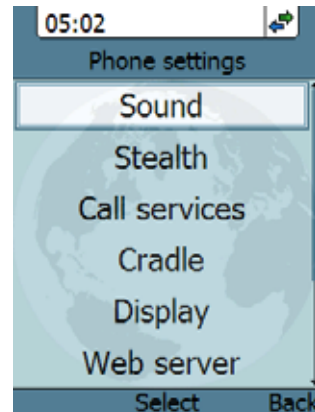



### To adjust the sound

You can adjust the ringing tone, the tone volume and the keypad click.

To adjust the sounds of the handset, do as follows:

1. From the **Settings** menu, select **Sound**.
2. Use the arrow keys to move to the sound you want to adjust.
3. For **Keypad click**, select **Edit** to change the setting.
4. For the other settings, use the keys ◀ and ▶ to change the setting, or select **Edit**, select the setting you want and select **OK**.

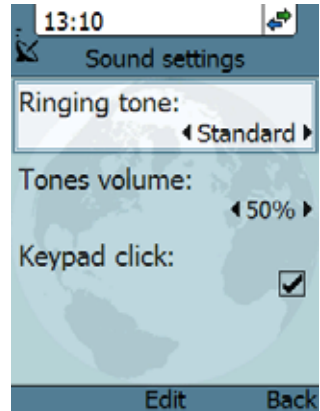

### To set up stealth mode

Stealth mode is used when the IP Handset should not be noticed. In stealth mode you can turn off all lights in the display and/or sounds for external events. Note, however, that the keypad will still light up when you press a key.

To configure and go into stealth mode, do as follows:

1. From the **Settings** menu, select **Stealth**.
2. Move to **Suppress audio** and/or **Suppress backlight** and select **Edit** to change the setting.

#### Note

These settings are only activated when **Use stealth** is checked.

3. Move to **Use stealth** and press **Edit** to check/clear the box.

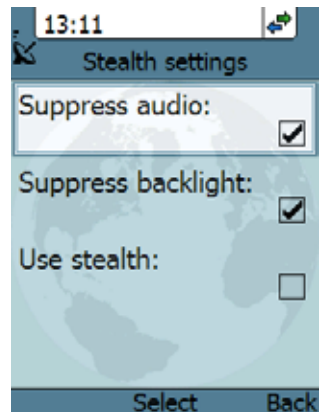

4. When stealth is set up and **Use Stealth** is selected in this menu, you can activate and deactivate it from the main screen by selecting **Options > Stealth**.

### *To set call services (Noise cancellation and Automatic secure)*

The IP Handset has efficient noise suppression software which you can switch on or off, depending on the noise level in your environment. Noise cancellation should only be selected when the handset is used in a noisy environment.

To set up Noise cancellation, do as follows:

1. From the **Settings** menu, select **Call services**.
2. Press **Select** for **Noise cancellation**.

When the IP Handset is used in networks where all calls must be secure, it can be set up to start a secure session automatically each time when a call is initiated and the peer IP Handset goes off-hook.

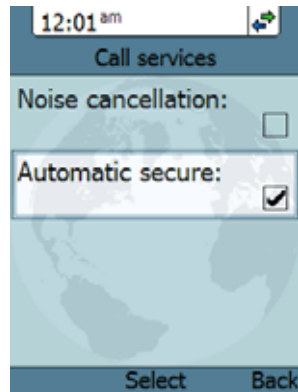

To set up **Automatic secure**, do as follows:

1. From the **Settings** menu, select **Call services**.
2. Press **Select** for **Automatic secure** for all calls to be encrypted secure calls.

**Note**

If you want to make a single secure call do not select **Automatic secure**. Use the option **Go secure**, proceed as described in *To make a secure call* on page 49.

### To set up the function of the cradle

The IP Handset can be operated as hand-held or hands-free. You can select whether the handset should detect the cradle or not.

To set up the cradle settings, do as follows:

1. From the **Settings** menu, select **Cradle**.
2. To have the handset detect whether or not it is in the cradle, check the box. This is the default mode. The function is as follows:
  - You can answer calls by removing the handset from the cradle, and terminate a call by putting the handset back in the cradle.
  - The handset automatically changes to hands-free when you make or answer a call with the handset in the cradle.
  - If you take the handset from the cradle during the call, it automatically changes to hand-held operation.
  - In hand-held mode, when you put the handset in the cradle, the call is terminated.
  - In hands-free mode, when you put the handset in the cradle the call is not affected.
3. To make the handset independent of the cradle, clear the box. This means you must always use **∕** or **#** and **☎** to start and end calls, and you can only enable or disable hands-free operation by using the keypad.

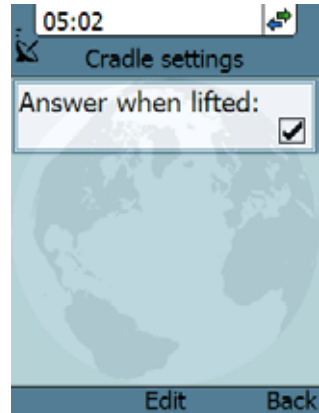

### To set up the display

You can customize the following items in the display:

- Active backlight can be adjusted from 10 to 100 percent. The backlight is on for 15 seconds after the last key press.
- Standby backlight can be adjusted from 0 to 50 percent and cannot be set higher than the current Active backlight
- Screensaver, you can select whether the IP Handset should use a screen saver when it is not used for one minute.
- Transparency can be selected.
- Automatic day/night mode can be selected. This automatically gives you optimum display light conditions, also for operation in low light areas. If you do not want to use automatic activation, deselect it. You can still start it manually from the Main Options menu when needed. For further details see *To use night mode* on page 53.

To set up the display settings, do as follows:

1. From the **Settings** menu, select **Display**.
2. Move to the setting you want to change.
3. For the backlight settings, use the keys ◀ and ▶ to change the percentage.
4. For the remaining settings, select **Edit** to and select or deselect the item.

**Note** Use the down key to scroll down to Automatic Day/night mode.

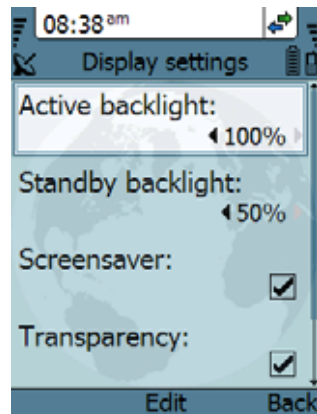

### To set or disable automatic shut down

You can set up the wireless IP Handset to shut down automatically if it does not receive a signal from a wireless access point for a certain period of time.

To set or disable automatic shut down, do as follows:

1. From the **Settings** menu, select **Automatic shut down**.
2. Use the keys ◀ and ▶, or press **Edit** to select the wanted time interval before auto power off. You have the following choices:
  - Disabled
  - 2, 5, 15, 30 or 60 minutes
3. Select the time span and press **Back**.

### To enable or disable the web server

A web server is built into the IP Handset. It is primarily used for uploading software and for editing contacts in the IP Handset. You can enable or disable the web server.

To enable or disable the built-in web server, do as follows:

1. From the **Settings** menu, select **Web server**.
2. Select **Edit** to enable or disable the web server. The default settings is enabled (checked).

For information on the web server, see *Using the web server* on page 87.

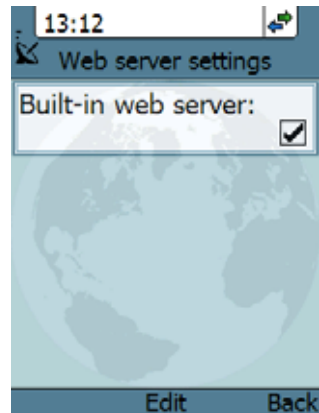

### To set the date and time

**Note** | The date and time is only maintained as long as the handset is powered!

To set the date and time, do as follows:

1. From the **Settings** menu, select **Date and time**.
2. If your handset is connected to a BGAN terminal and you want to use the UTC time received from the BGAN satellite, select **Use BGAN time**. Then leave the menu.
3. If you want to set the date and time manually, clear the **Use BGAN time** box. Then continue to the following steps.
4. To change the time, move to **Time:** and press **Edit**. Then type in the new time and select **OK**. The new time is activated immediately.
5. To change the date, move to **Date:** and press **Edit**. Then type in the new date and select **OK**.
6. To switch the time format between 24h and 12h, use the keys ◀ and ▶, or select **Edit** and select the wanted format.
7. To change the time zone, use the keys ◀ and ▶, or select **Edit** and select the wanted time zone.

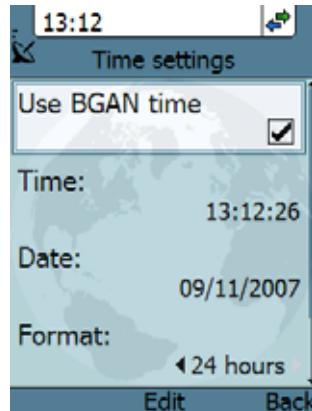

**Note** | Use the down key to scroll down to the last item in this sub menu.

### To select the language

This setting is for future use. Only English language is currently available.

### To apply factory default settings

You can reset the IP Handset to factory default settings.

To return to factory default for all settings, do as follows:

1. From the **Settings** menu, select **Factory default**.

**Important**

All settings and status information are lost when you accept this setting!

2. Select **Yes**.

All settings and status information are now changed to factory default settings. Note that in some cases this operation may take up to 30 seconds.

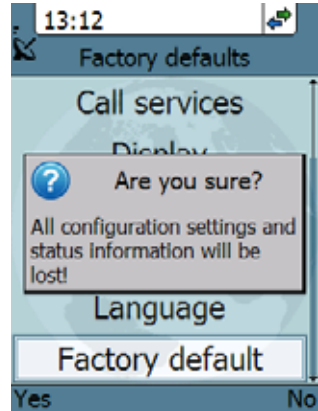

## SIP telephony and profiles

The IP Handset has an integrated SIP (Session Initiation Protocol) client used for SIP telephony between the IP Handset and the BGAN terminal, which has an integrated SIP server, or another SIP server. How to set up the SIP profile depends on your subscription and the SIP server and network to which the IP Handset is connected to.

### *To activate a SIP profile*

The default profile is the BGAN profile, which is used when the IP Handset is connected to a BGAN terminal.

To activate a profile, do as follows:

1. From the main menu, select **SIP**.
2. Move to the profile you want to use for communication, and select **Connect**.

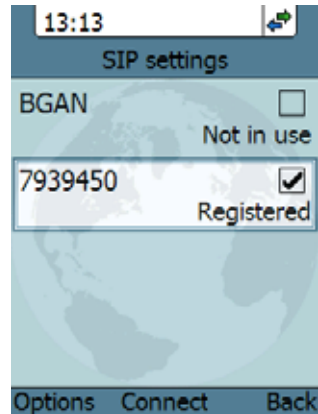



### To add a new SIP profile

Add a new SIP profile if you want to connect the SIP client of the IP Handset to a SIP server. You need to enter several network specific values so the IP Handset can communicate with the SIP server. The IP Handset can hold up to 10 profiles.

The following parameters can be set up in the SIP profile:

- Profile name
- SIP server and port
- User name
- Password
- Codec priority
- STUN server
- Reregister interval

To add a new SIP profile, do as follows:

1. In the SIP menu, select **Options** (left select key).
2. Select **Add**.

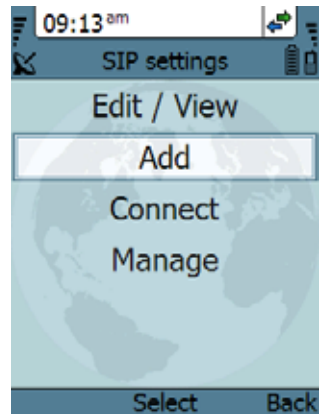

3. Type in the name to use for the new profile and select **OK**.  
**Example:** The profile name is New Profile.
4. Move to **SIP server** and select **Edit**.



5. At **Server name / IP:**, select **Edit** again.
6. Type in the server name (URL) or IP address and select **OK**.  
**Example:** Server name is voip.serv.
7. Type in the port number for the SIP server and select **OK**.  
**Example:** Port number is 5060 (default setting),
8. Select **Back** to continue the set up of the remaining parameters.

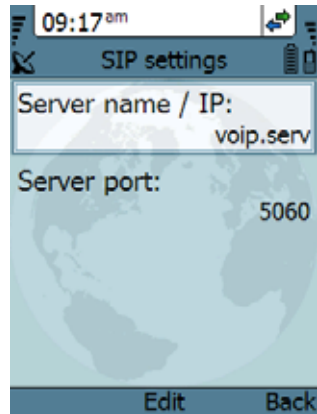

9. Move to the setting you want to change and select **Edit**. Type in the information and enter with **OK**.

**Note**

Use the down key to scroll down to the last items in this sub menu.

- **User name:** When connecting to a BGAN terminal, the user name should be the same as the local number for the handset.
- **Password:** When connecting to a BGAN terminal, the password must match the IP Handset password entered in the terminal.
- **Codec priority:** Select the codec type that should have the highest priority. You may select G.711 or G.729 A/B.
- **STUN server:** If your SIP telephony installation requires a STUN server name, you can enter it here. Refer to the documentation of the SIP server.
- **Reregister every:** This settings sets the time interval in which the IP Handset registers with the SIP server it is connected to. If the SIP server is the BGAN terminal, you don't need to change this setting. The interval is set to 120 seconds (default). The maximum value is 86400 seconds (24 hours).  
If the connection to an external SIP provider is made through a NAT router, this setting may be needed to keep the connection through NAT to the SIP server open. This setting should in this case typically be set to 20 seconds.

**Note**

If the IP Handset registers with the SIP server over a satellite connection or other telecommunications network you may set this time interval to a larger value to avoid unintended use of bandwidth.

10. When you have made the changes, select **Back**.



11. If you want to connect immediately with the new SIP profile, select **Connect**. If not, select **Back** to leave the menu.

### *To edit a SIP profile*

To edit a SIP profile, do as follows:

1. In the list of profiles, go to the profile you want to change and select **Options > Edit/View**.
2. Edit the settings as described in the previous section.

#### **Note**

For the BGAN profile, only the user name and password can be changed. The default user name and password are 0501 and 0501.

### *To delete a SIP profile*

To delete a SIP profile, do as follows:

1. In the SIP menu, move to the profile you want to delete and select **Options**.
2. Select **Delete**.
3. Select **Yes**.

### To delete all SIP profiles

To delete all SIP profiles, do as follows:

1. From the SIP settings menu, select **Options** (left select key).
2. Select **Manage**.
3. Select **Delete all**.

#### Important

All profiles except BGAN are deleted - this means that you will only be able to connect your handset using the BGAN profile.

4. Select **Yes**.

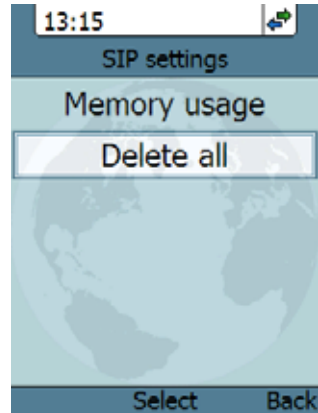

### To see memory usage in the list of SIP profiles

To see the number of profiles in the list and the maximum allowed number of profiles, do as follows:

1. From the SIP settings menu, select **Options** (left select key).
2. Select **Manage**.
3. Select **Memory usage**.

## Information from the BGAN terminal

When the IP Handset is connected to a BGAN terminal, the handset provides a dedicated **BGAN** menu. Through this menu you have access to a subset of controls and views of the BGAN terminal.

You find the following items in the BGAN terminal menu:

- **Connect:** You can use the IP Handset with the local number 0501 to start and stop IP background or streaming connections for all network user groups.
- **Status** with current GPS position, status, signal strength and PIN status.
- **Properties** with information about the BGAN terminal type and software version.
- **Enter PIN code:** If needed
- **Active alarms** in the BGAN terminal (if any).

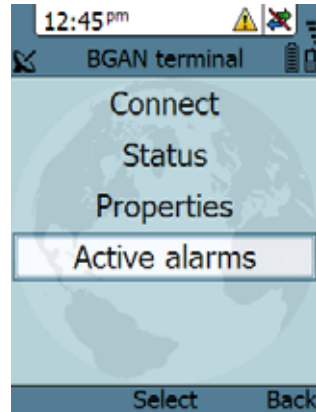

Each item is explained in detail in the following sections. To access the BGAN menu, select **BGAN** from the main menu.

### *To start and stop IP background or streaming connections (0501 only)*

You can use the IP Handset that has the local number 0501 to start or stop data connections set up in the network user groups of the BGAN terminal. The network user groups and types of data connections are configured in the web interface of the BGAN terminal. With this functionality you do not need to connect a PC to the BGAN terminal to start or stop IP background or streaming connections for devices connected to the BGAN terminal.

To start and stop IP standard or streaming connections set up in the BGAN terminal, do as follows:

1. From the **BGAN** menu, select **Connect**.
2. Use the left/right keys to find the network user group for the application you want to start or stop.
3. Use the up/down keys to select the connection you wish to start (Active) or stop (Inactive).
4. Press **Start** to start a connection, or press **Stop** to stop the connection.
5. A confirmation window is displayed. Press **Yes** to continue.

The IP Handset sends a command to the BGAN terminal to start or stop the selected connection. Check the IP Handset at regular intervals that the connection is still running.

If the connection could not be started by the BGAN terminal, the check mark will be removed, the connection is inactive and the command **Stop** has changed to **Start**.

For detailed information about using IP data connections and setting up network user groups with standard and streaming profiles refer to the terminal's user manual.

**Note**

**Optimize airtime and bandwidth usage:** You must manually stop the connection when not used any longer. Note that you are charged for the bandwidth used and the data transferred.

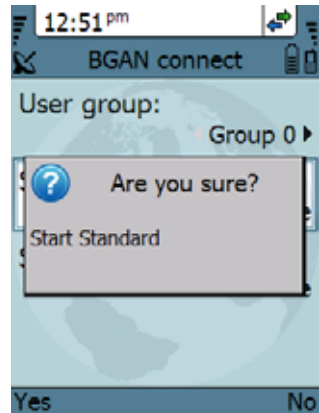
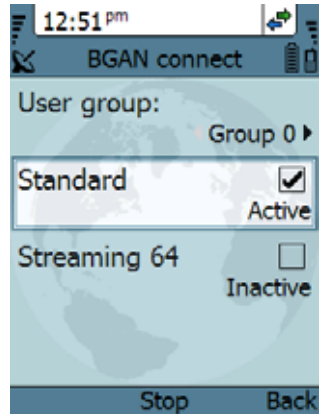

### To see *BGAN status information*

To see the BGAN status, do as follows:

1. From the **BGAN** menu select **Status**.

The status menu shows the following information:

- **GPS position** shows the current position of the BGAN system.
- **Status** shows the status of the BGAN connection, for example Ready or Registering.
- **CNo** shows the signal strength of the BGAN connection (the carrier-to-noise ratio).
- **PIN status** shows status of the PIN, for example whether the terminal is waiting for a PIN.



### To see *BGAN terminal properties*

To see the BGAN terminal type and software version, do as follows:

1. From the **BGAN** menu select **Properties**.
2. Click **Ok** or **Back** to return to the BGAN menu.



### To enter the PIN for the BGAN terminal

Note that this menu item is only available if the BGAN terminal is waiting for a PIN.

To enter the PIN for the BGAN terminal, do as follows:

1. From the **BGAN** menu select **Enter PIN code**.
2. Type in the Administrator user name for the terminal and select **OK**.  
For information on how to type text in the handset, see *How to enter text in the IP Handset* on page 54.
3. Type in the Administrator password for the terminal and select **OK**.
4. Type in the PIN for the terminal and select **OK**.

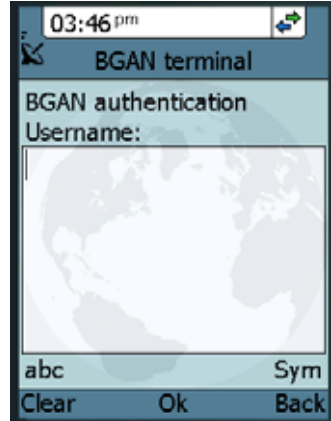

### Alarm from the BGAN terminal

You can use the IP Handset to alert you when there is a critical alarm in the BGAN terminal. A critical alarm covers warnings and error messages issued by the BGAN terminal.

Press **Details** to see further information about the alarm, or press **Exit** to return to normal phone operation.

As long as the alarm condition is present in the terminal the yellow alarm icon is displayed in the IP Handset display. When there is no active alarm in the terminal, the alarm icon disappears.

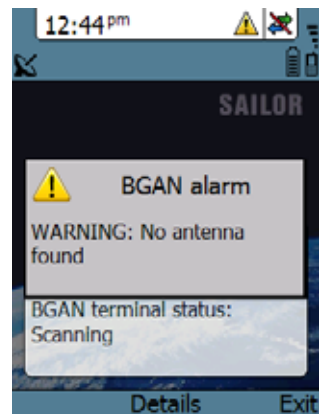

Refer to the BGAN terminal's user manual for further details on critical alarms and how to solve them.

### *Displaying active alarms from the BGAN terminal*

Besides the alarm alert you can display a list over active alarms and click for details for each active alarm.

To read BGAN terminal alarms, do as follows:

1. From the main menu, select **BGAN**.
2. If there are active alarms in the BGAN terminal, you can select **Active alarms**.
3. Press **Select** to access the list of active alarms.
4. Scroll to an alarm and press **Select** to display details about this particular alarm.
5. Press **Ok** or **Back** to return to normal phone operation.

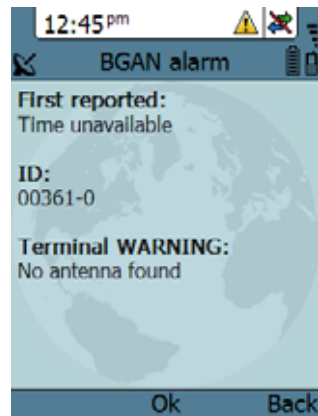

# Using the web server

This chapter describes how to use the web server in your IP Handset system.

## Introduction to the web server

The web server is built into the IP Handset and is primarily used for uploading software and for editing contacts in the IP Handset.

You can access the web server from a computer connected to the BGAN terminal you are using for the IP Handset. Use a standard Internet browser.

## Browser settings

If you are connecting your computer using a LAN or WLAN interface, the **Proxy server** settings in your browser must be disabled before accessing the web interface. Most browsers support disabling of the Proxy server settings for one specific IP address, so you can disable Proxy server settings for the web interface only, if you wish. Consult your browser help for information.

To disable the use of a Proxy server completely, do as follows:

**Note**

The following description is for **Microsoft Internet Explorer**. If you are using a different browser, the procedure may be different.

1. In Microsoft Internet Explorer, select **Tools > Internet Options > Connections > LAN Settings**.

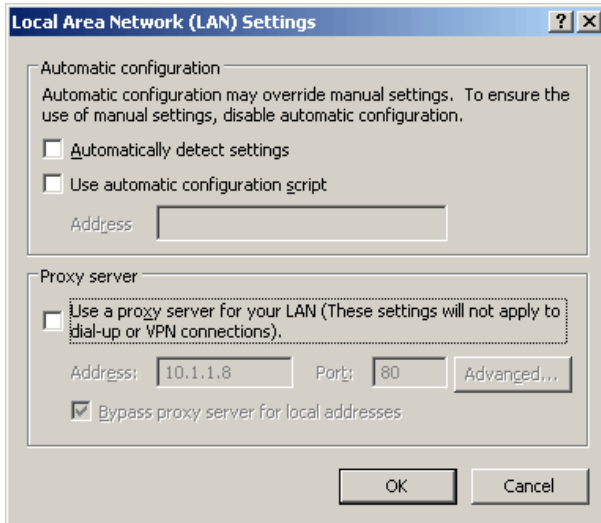

2. Clear the box labeled **Use a proxy server for your LAN**.
3. Click **OK**.

When the proxy server settings are disabled, close your browser.

You may need to change this setting back on return to your Internet connection.

## Accessing and navigating the web server

**Note**

The following procedure is valid if the IP Handset is used together with a BGAN terminal.

### To access the web server of the IP Handset

To access the web server from a computer, do as follows:

1. Start up your computer, the BGAN terminal and the IP Handset.
2. Connect your computer to the BGAN terminal using a standard LAN cable.
3. Connect your IP Handset to the BGAN terminal as described in *Getting started* on page 7.
4. Open your browser on the computer and enter the IP address of the IP Handset. You find the IP address in the handset menus under **Status > Network information**.

Another way to access the web interface of the IP Handset is to click on the page **SETTINGS > IP handsets > Configure** link in the web interface of the terminal.

You can also see the IP address in the web interface of the terminal on the page **SETTINGS > IP handsets**. Move the cursor to **Configure** for the handset. Its IP address is shown in the status line in the lower left corner of the window.

## Overview of the web server

The web server consists of the following sections.

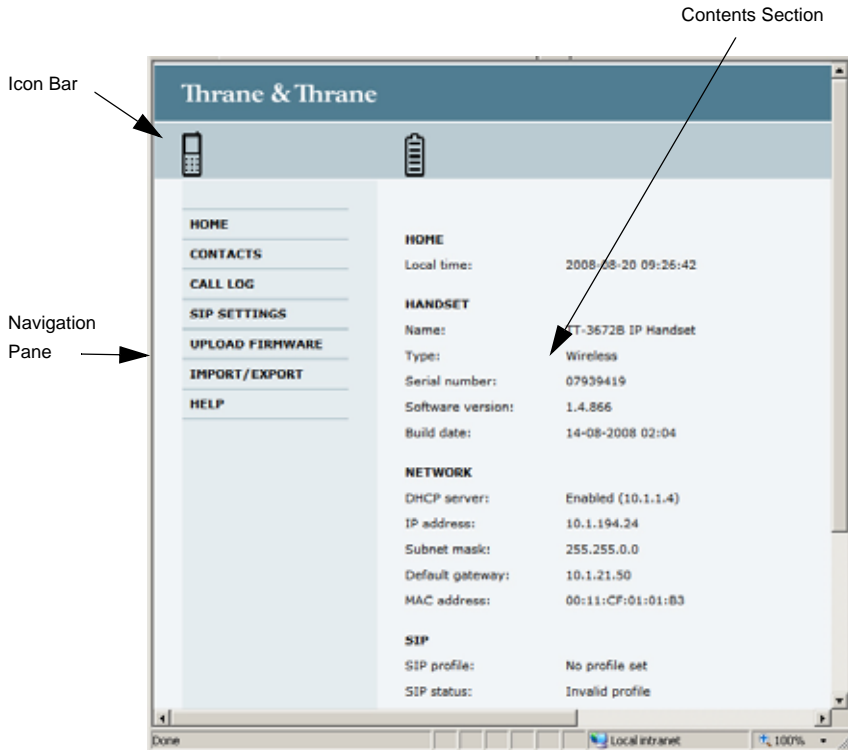

- The **navigation pane** holds the main menu. Clicking an item in the menu opens a submenu in the navigation pane or a new page in the contents section.
- The **icon bar** shows a handset icon to indicate that it is the internal web server of the IP Handset (and not of a BGAN terminal). If the handset is wireless, a battery icon shows the status of the battery. When you pass the cursor over the battery icon a text shows the status, e.g. “Battery: 67%, charging”.
- The **contents section** shows the page selected in the navigation pane. This section is used for viewing or changing settings, or for performing actions.

# Using the web server

## The Home page

The web server starts up on the Home page. To go back to the Home page from another location in the web server, select **Home** from the left navigation pane.

The Home page shows properties and network settings of the handset. The page is automatically updated every 5 seconds.





## Contacts

The web server gives access to the Contacts list of the handset.

Select **CONTACTS** from the left navigation pane. The page shows the name and number of all contacts in the handset.

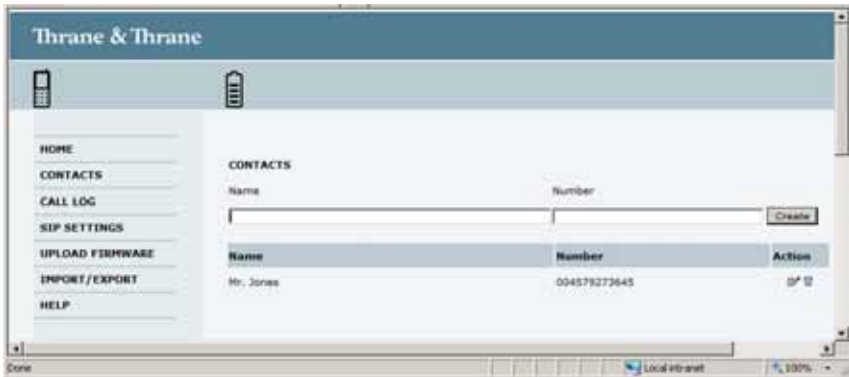
You can sort the list by name or number by clicking **Name** or **Number** in the heading row of the list.



- To add a new contact, type in the name and number at the top of the page and click **Create**. The Contacts list can hold 100 entries.
- To delete a contact, click  next to the contact you want to delete.
- To edit a contact, click  next to the contact you want to edit, and make your corrections.



## Call log

To display the call log of the handset, select **CALL LOG** from the left navigation pane.

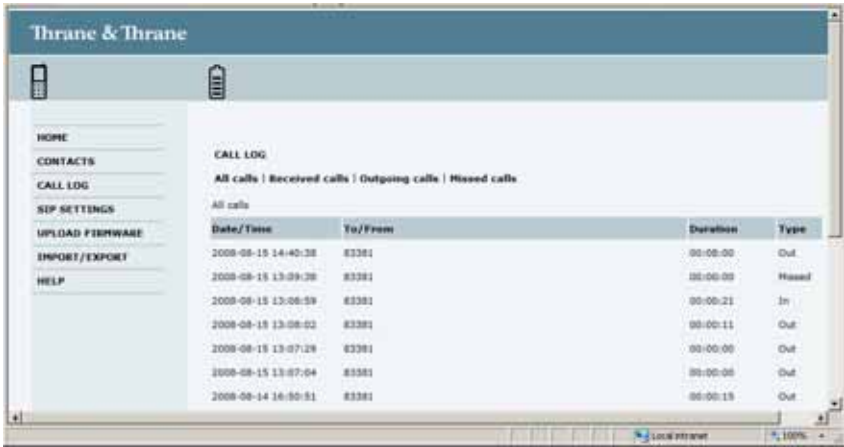

For each call the **CALL LOG** page shows date and time, phone number, duration and whether the call was incoming, outgoing or missed. If the phone number is in the Contacts list, the name of the contact is shown with the number. The latest calls are listed first.

If you only want to see a subset of the calls, select one of the sub-groups at the top of the page. You can select **Received calls**, **Outgoing calls** or **Missed calls**.

## SIP settings

### Overview

The handset communicates using SIP (Session Initiation Protocol).

To view the SIP settings of the handset, select **SIP SETTINGS** from the left navigation pane. The page shows the settings for the current SIP profile.

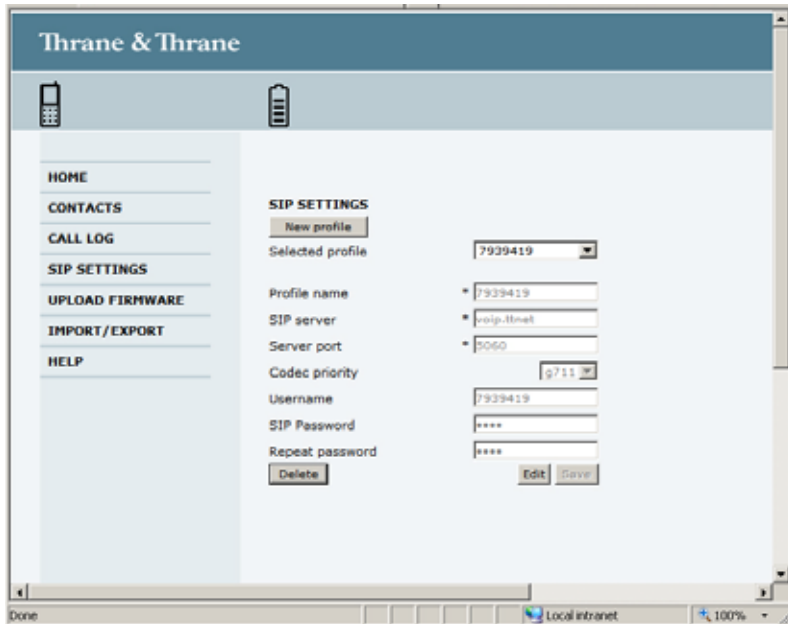

### *To add a new SIP profile*

The list of SIP profiles can hold maximum 10 profiles. To add a new profile, do as follows:

1. Click **New profile** at the top of the page.
2. Fill in the list.  
You may not need to fill in all items in the list. Mandatory fields are marked with \*.
3. Click **Save** at the bottom of the page.

### *To edit a SIP profile*

To edit a SIP profile, do as follows:

1. From the **Profile** scroll list select the profile you want to edit.
2. Change the settings according to your needs.

**Note**

For the BGAN profile, you can only change the user name and password. Be careful if you change these - the user name is also the local phone number.

3. Click **Save** at the bottom of the page.

### *To delete a SIP profile*

To delete a SIP profile, do as follows:

1. From the **Profile** scroll list select the profile you want to delete.
2. Click **Delete** at the bottom of the page.

## Uploading firmware

You can use the web server to upload firmware from your computer to the IP Handset.

To upload firmware, do as follows:

1. Select **UPLOAD FIRMWARE** from the left navigation pane.

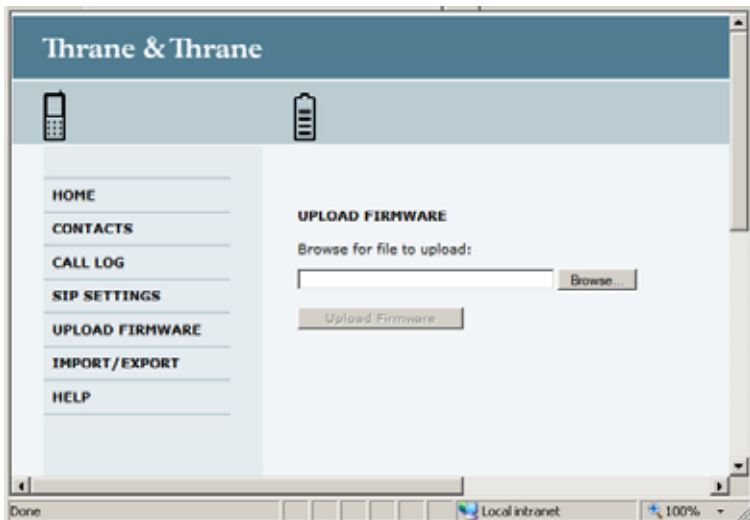

2. Click **Browse** and locate the firmware you want to upload to the IP Handset.
3. Click **Upload firmware**.

The handset initiates firmware upload, showing the progress in the display. When upload is done, the handset automatically restarts with the new firmware.

**Note**

After uploading firmware to the handset, you may have to refresh your Internet browser for the web server to display correctly. To refresh the browser, press <F5>.

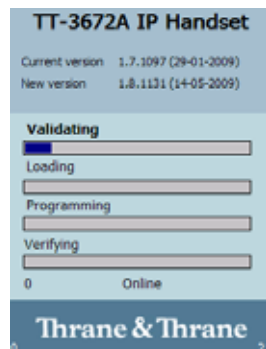

## Import and Export settings

If you want to copy settings from one handset to another you can use the Import/Export function. You can import settings to your handset from a file, or export settings from the handset to a file. Select **IMPORT/EXPORT** from the left navigation pane.

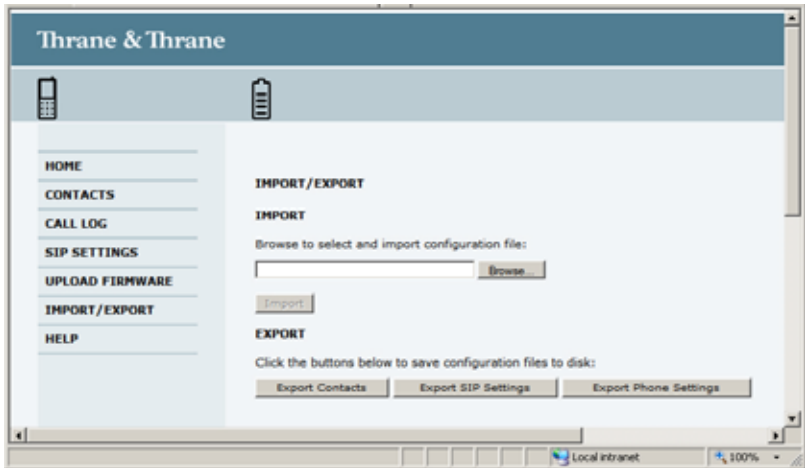

### To export settings to a file

You may export three types of settings file, each containing a subset of the handset settings: Contacts, SIP settings or Phone settings. The name of the file indicates which settings are included in the file.

To export a subset of the settings to a file, do as follows:

1. In the **IMPORT/EXPORT** page, click a button under **EXPORT** to create a settings file.
2. Click **Save**, browse to the location where you want the settings file, and click **Save** again.

The file is now saved in the location you specified.

### *To import settings from a file*

You can import three types of settings file, each containing a subset of the handset settings: Contacts, SIP settings or Phone settings. The name of the file indicates which settings are included in the file.

To import a settings file, do as follows:

1. Click **Browse**.
2. Browse to the location where the settings file is saved and select the file you want to import.
3. Click **Open**.
4. Click **Import**.

The selected settings are now replaced by the imported settings.

## Help and diagnostics report

The IP Handset can generate a diagnostics report. This report includes information that can be very useful for a service technician. If you are reporting an error with your IP Handset, you may be asked to provide a diagnostics report. To save a diagnostics report, do as follows:

1. Select **HELP** from the left navigation pane.

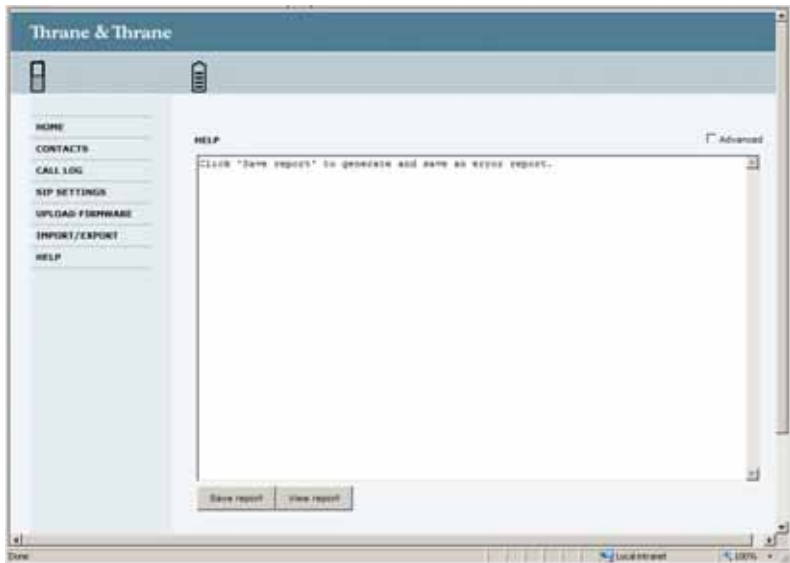

2. Click **Save report**.

3. If your service technician needs specific information included in the report, click **Advanced** and select the items needed. Then click **Save report**.

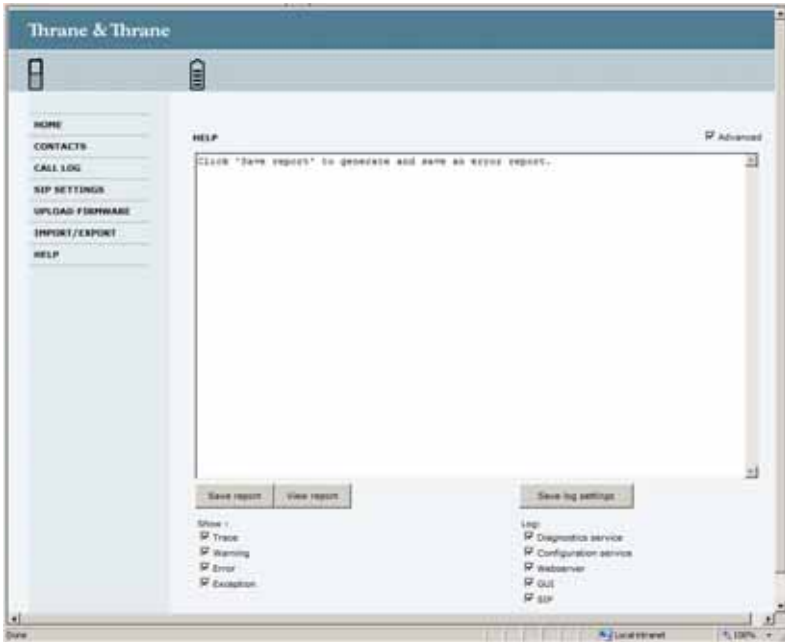



## Service & maintenance

This chapter gives guidelines for getting support, general maintenance tasks and troubleshooting,

### Getting support

If this manual does not provide the information required to solve your problem, you may want to contact your Airtime Provider or your supplier.

If you can see that the problem is related to airtime and not to your IP Handset, please contact your Airtime Provider

If you need assistance with problems caused by the IP Handset, please call a distributor in your area. You may be asked to generate a diagnostics report. For information on how to generate a report, see *Help and diagnostics report* on page 99.

An updated list of distributors is available on Thrane & Thrane's web site: [www.thrane.com](http://www.thrane.com).

## Maintenance tasks

Carefully read and follow the instructions on maintenance of the IP Handset. Failure to carefully observe the following procedures and precautions can result in leakage of battery fluid, permanently damage batteries and serious personal injury!

### Software update

For instructions how to make a software update see *Uploading firmware* on page 96.

### Battery handling for the wireless IP Handset

- Do not dismantle, open or shred the IP Handset. It should be dismantled only by trained personnel.<sup>1</sup>
- Do not expose the IP Handset or batteries to heat or fire. Avoid storage in direct sunlight.
- Do not subject the IP Handset or batteries to mechanical shock.

#### Note

If the IP Handset is out of use for a longer period of time, recharge the battery every two years to avoid deterioration of the battery.

### Leaking battery

In the event of an IP Handset leaking liquid, do not allow the liquid to come into contact with the skin or eyes. If contact has been made, wash the affected area with copious amounts of water and seek medical advice.

- 
1. **Exception:** You must remove the battery before disposing of the IP Handset. For details how to proceed see *To remove the battery from the IP Handset* on page 103.

## Cleaning the IP Handset

Wipe the IP Handset or cradle with a clean dry cloth if they become dirty. Make sure that the charging contacts of the handset and cradle are clean.

## Disposal of the IP Handset

Old electrical and electronic equipment marked with this symbol can contain substances hazardous to human beings and the environment. Never dispose these items together with unsorted municipal waste (household waste). In order to protect the environment and ensure the correct recycling of old equipment as well as the re-utilization of individual components, use either public collection or private collection by the local distributor of old electrical and electronic equipment marked with this symbol.



Contact the local distributor for information about what type of return system to use.

### Important

Take out the battery before disposing of the IP Handset. The battery must be disposed of separately.

### *To remove the battery from the IP Handset*

You need the following tools:

- Torx screw driver size TX05
- Torx screw driver size TX06
- Pair of tweezers

To remove the battery, do as follows:

1. Use the tweezers to remove the two rubber strips on the side of the IP Handset.
2. Use the Torx screwdriver size TX05 to remove 3 screws on each side.
3. Take off both aluminium side pieces.
4. Use the Torx screwdriver size TX05 to remove 2 screws at the bottom on the back.
5. Use the tweezers to open the IP Handset.



6. Use the Torx screwdriver size TX06 to remove 6 screws at the back.

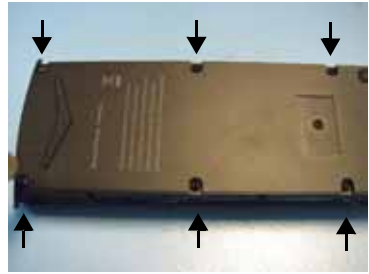

7. Take out the battery. It is glued to the board, you may need to use some force. Tear the flat cable out of the connector.
8. Dispose of the IP Handset and the battery safely according to local laws and regulations.



## Troubleshooting guide

The below table provides information on some of the problems that might occur, including possible causes and remedies to solve the problems.

Problem	Possible Cause	Remedy
The handset is not responding to any keys pressed.	An error occurred in the software.	Press and hold the on hook key for at least 10 seconds to switch off the handset. Then switch on the handset again.
No connection to the BGAN network.	<p>1) The PIN code has not been entered in the BGAN terminal,</p> <p>2) There is an error in the terminal or the BGAN network.</p>	<p>1) Enter the menu system of the handset and select <b>BGAN &gt; Enter PIN code</b>. For information on how to enter the PIN, see <i>Establishing a connection using BGAN terminal</i> on page 21.</p> <p>2) See the manuals for the BGAN terminal for information on how to troubleshoot errors.</p>
The handset shows “SIP fault”	No SIP profile is selected, the selected SIP profile is invalid, or the user name or password is wrong.	Enter the menu system and select <b>SIP</b> to see the selected profile. Change the profile or select another profile if necessary. For further information, see <i>SIP telephony and profiles</i> on page 76.

## Technical specifications

This appendix contains specifications and outline drawings for the wired IP Handset and cradle and the wireless IP Handset and cradle.

### Thrane IP Handset, wired

#### Specifications, wired handset

Item	Specification
Type	TT-3672A Thrane IP Handset, wired
Dimensions (L x B x H)	152 mm x 55 mm x 26.5 mm
Weight	190 g $\pm$ 20 g (without cable)
Display	2.2", 240 x 320 pixel TFT color LCD
Operating temperature	-25°C to +45°C
Storage and transport temperature	-25°C to +55°C
Humidity	Up to 95% without condensation
Air pressure, transport	4572 m AMSL

## Appendix A: Technical specifications

---

<b>Item</b>	<b>Specification</b>
Power	Power over Ethernet (PoE) class 2 (Alternative B of IEEE802.3af is not supported.)
Power consumption	Max. 7 Watt
Protection category	IP55, dust proof and splash proof
LAN interface	10/100 Mbps
Network Protocol	Internet Protocol (IP)
VoIP Protocol	SIP v2 Session Initiation Protocol (RFC3261), SDP (RFC2327)
Voice Codecs	G.711 and G.729 A/B
Physical interfaces	RJ-45 male connector on fixed cable  Not currently used: Headset 2.5 mm jack and Mini-USB 5-pin
Certifications	FCC, CE
Encryption (VoIP protocol)	SRTP (RFC 3711), ZRTP (ID ver. 3),
Compass safe distance	Wired handset: 50 cm  Wired cradle: 85 cm



## Outline dimensions, wired handset

Weight of Handset:  
 175 gram +/- 20 gram  
 Exclusive Wire

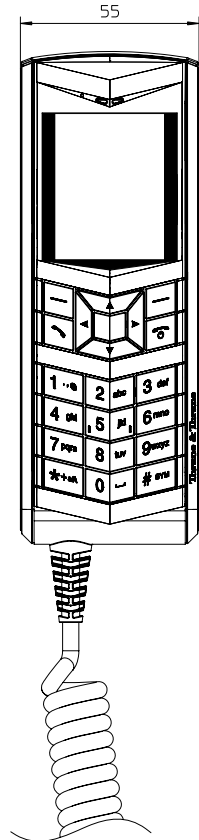
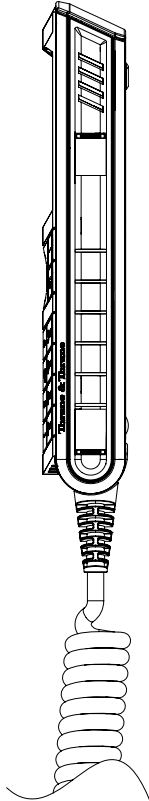
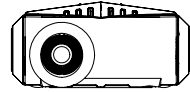

PERSPECTIVE VIEW

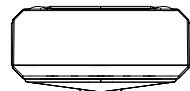

IP Handset, wired, outline dimensions, continued (side view and back view).

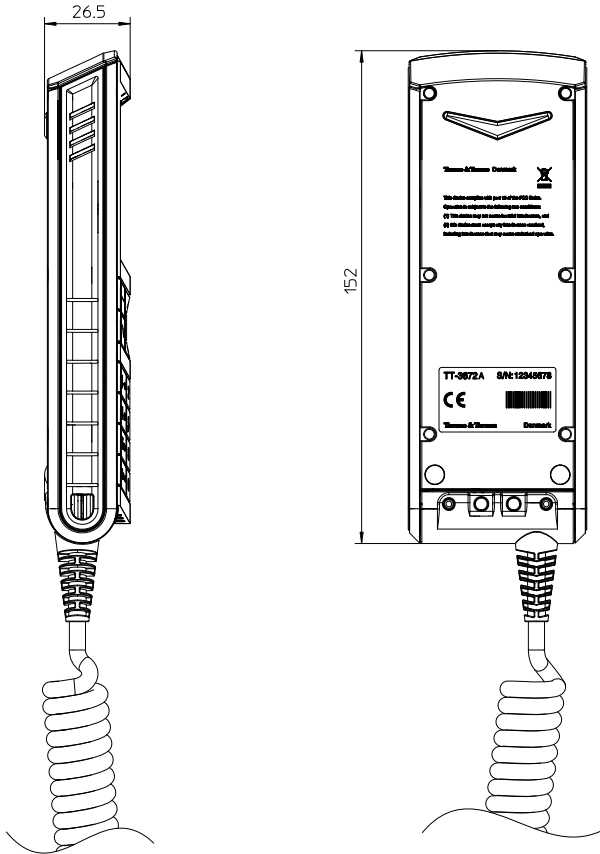

## Thrane IP Handset, wireless

### Specifications, wireless handset

Item	Specification
Type	TT-3672B Thrane IP Handset, wireless
Dimensions (L x B x H)	152 mm x 55 mm x 26.5 mm
Weight	190 g $\pm$ 20 g
Display	2.2", 240 x 320 pixel TFT color LCD
Operating temperature	0°C to +45°C
Storage temperature	Long term (>6 months) -20°C to +25°C Short term (<6 months) -20°C to +45°C
Temperature, transport	-25°C to +55°C
Humidity	Up to 95% without condensation
Protection category	IP55, dust proof and splash proof
Air pressure, transport	4572m AMSL
Battery	Li-Ion 1900 mAh
Charge power (in cradle)	10-32 V DC, 7 W max
Standby time	Up to 24 hours

## Appendix A: Technical specifications

---

<b>Item</b>	<b>Specification</b>
Talk time	Up to 4 hours
Wireless network interface	Wireless Local Area Network (WLAN) according to 802.11b/g
Network Protocol	Internet Protocol (IP)
VoIP Protocol	SIP v2 Session Initiation Protocol (RFC3261), SDP (RFC2327)
Voice Codecs	G.711 and G.729 A/B
Physical interfaces	Headset 2.5 mm jack Mini-USB 5-pin (charging only)
Certifications	FCC, CE, IC, SAR
Encryption (VoIP protocol)	SRTP (RFC 3711), ZRTP (ID ver. 3),
Compass safe distance	Wireless handset: 55 cm Wireless cradle: 90 cm

## Outline dimensions, wireless handset

Weight of Handset:  
175 gram +/- 20 gram

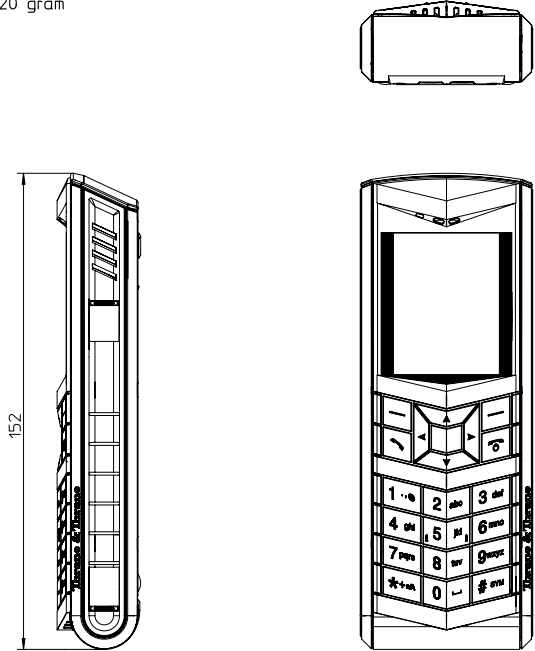

PERSPECTIVE VIEW

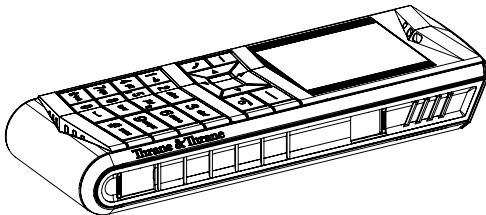

IP Handset, wireless, outline dimensions, continued (side view and back view).

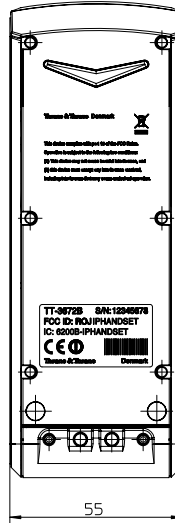
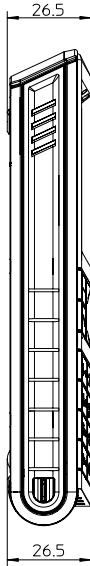

## Thrane IP cradle outline dimensions

The below outline drawing applies to both the wired and the wireless variant.

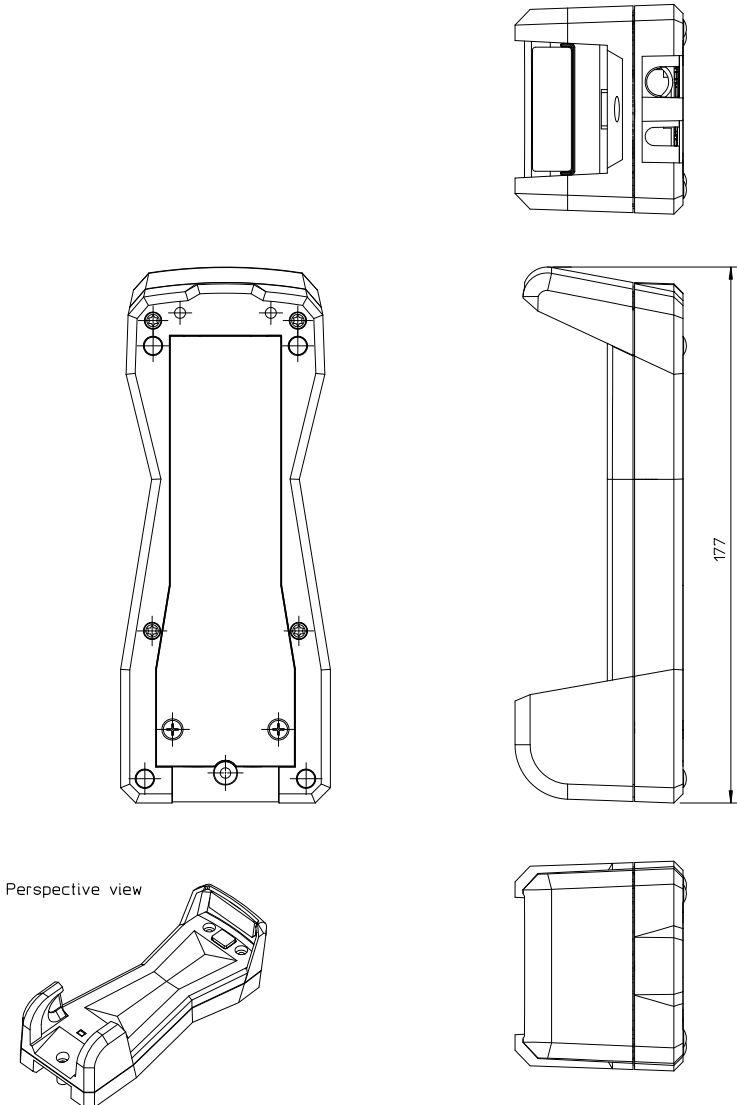

Thrane IP cradle outline dimensions, continued (front and side).

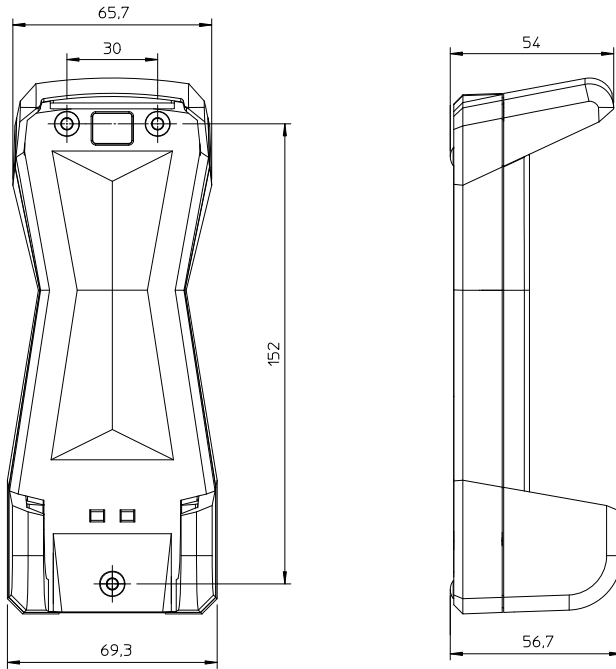



# Conformity

## Thrane IP Handset, wired

### CE (LVD & EMC)

The Thrane IP Handset, wired, is CE certified (LVD & EMC directives) as stated in the “Declaration of Conformity with LVD and EMC Directives”, enclosed in copy on the next page.

### FCC

Note: This equipment has been tested and found to comply with the limits for a Class A digital device, pursuant to Part 15 of the FCC Rules. These limits are designed to provide reasonable protection against harmful interference when the equipment is operated in a commercial environment. This equipment generates, uses, and can radiate radio frequency energy and, if not installed and used in accordance with the instruction manual, may cause harmful interference to radio communications. Operation of this equipment in a residential area is likely to cause harmful interference in which case the user will be required to correct the interference at his own expense.

# Thrane & Thrane A/S

## Declaration of Conformity with LVD and EMC Directives

The undersigned of this letter declares that the following equipment complies with the specifications of EC directive 73/23/EC concerning Low Voltage Safety and EC directive 89/336/EC concerning EMC.

### Equipment included in this declaration

TT-3670A Thrane IP Handset & Cradle, wired:  
TT-3672A Thrane IP Handset, wired PN = 403672A  
TT-3674A Thrane IP Cradle, wired PN = 403674A

### Equipment Applicability

The TT-3670A Thrane IP Handset is an IP telephone used worldwide for voice communication between the handset and a Thrane & Thrane BGAN terminal or any other IP terminal.

### Declaration

The safety requirement with respect to the LVD directive 73/23/EC is met by conforming to the harmonized EU standards EN 60950-1. The protection requirement with respect to the EMC directive 89/336/EC is met by conforming to the harmonized EU standards EN 60945 and EN 55022.

### Manufacturer

Thrane & Thrane A/S, Lundtoftegårdsvej 93D, DK-2800 Kgs. Lyngby, Denmark  
Porsvej 2, DK-9200 Aalborg SV, Denmark

### Place and Date

Kgs. Lyngby, 13. May 2008

  
Walther Thygesen, CEO  
Thrane & Thrane A/S

Doc. no. 99-127009-B



Page: 1 of 1

Thrane & Thrane A/S - Lundtoftegårdsvej 93D - DK-2800 Kgs. Lyngby - Denmark  
T +45 39 55 88 88 - F +45 39 55 88 88 - info@thrane.com - www.thrane.com  
Bank: Danske Bank - Corp. no. 142 22 60 28 - VAT: DK-20 64 64 60



# Thrane IP Handset, wireless

## CE (R&TTE)

The IP Handset is CE certified (R&TTE directive) as stated in "Declaration of Conformity with R&TTE Directive", enclosed in electronic copy on the next page.

## Use of WLAN

The WLAN interface requires that the user enters the current country of operation. See *To set the country for Wireless network use* on page 67.

For use in the EU, the following restrictions apply:

- France: Outdoor use must be limited to 10 mW EIRP within the frequency band 2454 MHz to 2483.5 MHz.
- Italy: Outdoor use outside own premises require general authorization

## FCC

Note: This equipment has been tested and found to comply with the limits for a Class B digital device, pursuant to part 15 of the FCC Rules. These limits are designed to provide reasonable protection against harmful interference in a residential installation. This equipment generates, uses and can radiate radio frequency energy and, if not installed and used in accordance with the instructions, may cause harmful interference to radio communications. However, there is no guarantee that interference will not occur in a particular installation. If this equipment does cause harmful interference to radio or television reception, which can be determined by turning the equipment off and on, the user is encouraged to try to correct the interference by one or more of the following measures:

- Reorient or relocate the receiving antenna.
- Increase the separation between the equipment and receiver.

- Connect the equipment into an outlet on a circuit different from that to which the receiver is connected.
- Consult the dealer or an experienced radio/TV technician for help.

See also the *FCC/IC Notice* on the next page.

### **Part 15.21**

Changes or modifications not expressly approved by the party responsible for compliance could void the user's authority to operate the equipment.

## FCC/IC Notice

To comply with FCC radiation exposure requirements, use of this device for head body operational configurations is limited to tested configurations and approved by Thrane & Thrane A/S.

### **THIS MODEL DEVICE MEETS THE GOVERNMENT'S REQUIREMENTS FOR EXPOSURE TO RADIO WAVES.**

Your wireless device is a radio transmitter and receiver. It is designed and manufactured not to exceed the emission limits for exposure to radio frequency (RF) energy set by the Federal Communications Commission of the U.S. Government. These limits are part of comprehensive guidelines and establish permitted levels of RF energy for the general population. The guidelines are based on standards that were developed by independent scientific organizations through periodic and thorough evaluation of scientific studies. The standards include a substantial safety margin designed to assure the safety of all persons, regardless of age and health.

The exposure standard for wireless devices employs a unit of measurement known as the Specific Absorption Rate, or SAR. The SAR limit set by the FCC is 1.6W/kg. Tests for SAR are conducted using standard operating positions specified by the FCC with the device transmitting at its highest certified power level in all tested frequency bands. Although the SAR is determined at the highest certified power level, the actual SAR level of the device while operating can be well below the maximum value. Before a device model is available for sale to the public, it must be tested and certified to the FCC that it does not exceed the limit established by the government-adopted requirement for safe exposure. The tests are performed in positions and locations (e.g., next to the head and body) as required by the FCC for each model. The FCC has granted an Equipment Authorization for this model device with all reported SAR levels evaluated as in compliance with the FCC RF emission guidelines. SAR information on this model device is on file with the FCC and can be found under the Display Grant section <http://www.fcc.gov/oet/fccid> after searching on FCC ID: ROJIPHANSET.

# Thrane & Thrane A/S

## Declaration of Conformity with R&TTE Directive

The undersigned of this letter declares that the following equipment complies with the specifications of EC directive 1999/5/EC concerning Radio & Telecommunications Terminal Equipment.

### Equipment included in this declaration

TT-3670B Thrane IP Handset & Cradle, wireless:  
TT-3672B Thrane IP Handset, wireless PN = 403672B  
TT-3674B Thrane IP Cradle, wireless PN = 403674B

### Equipment Applicability

The TT-3670B Thrane IP Handset wireless is an IP telephone used worldwide for voice communication between the handset and a Thrane & Thrane BGAN terminal with a WLAN access point or as a standard SIP compatible telephone over any WLAN network.

The WLAN band (2.4GHz) interface of the terminal has restrictive use in France and Italy in EU. The use of WLAN is controlled by a country code loaded in the terminal. See the User manual for further information.

### Declaration

The safety requirement with respect to the LVD directive 73/23/EC is met by conforming to the harmonized EU standard EN 60950-1. The protection requirement with respect to the EMC directive 89/336/EC is met by conforming to the harmonized EU standards ETSI EN 301489-1, ETSI EN 301489-17 and EN 60945. Effective use of frequency spectrum is met by conforming to the harmonized EU standard ETSI EN 300328.

### Manufacturer

Thrane & Thrane A/S, Lundtoftegårdsvej 93D, DK-2800 Kgs. Lyngby, Denmark  
Porsvej 2, DK-9200 Aalborg SV, Denmark

### Place and Date

Kgs. Lyngby, 30. June 2009



Walther Thygesen, CEO  
Thrane & Thrane A/S



Doc. no. 99-129717-A

Thrane & Thrane A/S • Lundtoftegårdsvej 93 D • DK-2800 Kgs. Lyngby • Denmark  
T +45 39 95 98 00 • F +45 39 95 88 88 • info@thrane.com • www.thrane.com  
Bank: Danske Bank • Cnr.no. 99 12 97 17 A 18 • VAS 38 20 64 66 66



Page: 1 of 1

**A**

AES                      Advanced Encryption Standard

**B**

BGAN                    Broadband Global Area Network. A mobile satellite service that offers high-speed data up to 492 kbps and voice telephony. BGAN enables users to access e-mail, corporate networks and the Internet, transfer files and make telephone calls.

**C**

CE                        Conformité Européenne. This term signifies that a CE certified product conforms to European health, environmental, and safety regulations. It makes the product legal to be sold in the European Union.

**D**

DHCP                    Dynamic Host Configuration Protocol. A protocol for assigning dynamic IP addresses to devices on a network. With dynamic addressing, a device can have a different IP address every time it connects to the network.

DNS                      Domain Name Server. A system translating server names (URLs) to server addresses.

**I**

IEEE                     Institute of Electrical and Electronics Engineers. IEEE is a non-profit organization and the world's leading professional association for the advancement of technology.

IMSO                    International Maritime Satellite Organisation

**IP** Internet Protocol. The method or protocol by which data is sent from one computer to another on the Internet.

### **L**

**LAN** Local Area Network

**LCD** Liquid Crystal Display

### **M**

**MAC** Media Access Control address. A hardware address that uniquely identifies each node of a network.

### **N**

**NAT** Network Address Translation.

### **P**

**PCB** Printed Circuit Board

**PIN** Personal Identification Number. A secret numeric password shared between a user and a system, used to authenticate the user to the system.

**PoE** Power over Ethernet. A standard for combining power supply with transmission of data over the Ethernet. The source unit "injects" power into the Ethernet cable and the power is "picked up" at the connected device.

**PSK** Pre-Shared Key

**PUK** PIN Unblocking Key. An eight-digit code used to unblock a SIM card after three incorrect PINs have been entered. The PUK code is supplied with the SIM card.



**Q**

**QVGA** Quarter Video Graphics Array. A popular term for a computer display with  $320 \times 240$  resolution. QVGA displays are often seen in mobile phones, PDAs and some handheld game consoles.

**R**

**RTP** Real-time Transport Protocol, defines a standardized packet format for delivering audio and video over the Internet.

**S**

**SA** Stronger Authentication

**SIM** Subscriber Identity Module. The SIM provides secure storing of the key identifying a mobile phone service subscriber but also subscription information, preferences and storage of text messages.

**SIP** Session Initiation Protocol. An application-layer control (signaling) protocol for creating, modifying, and terminating sessions with one or more participants. Used e.g. for Internet telephony.

**STUN** Simple Traversal of UDP through NATs, a protocol for assisting devices behind a NAT firewall or router with their packet routing.

**T**

**TFT** Thin Film Transistor. A display type using a number of individual display cells, each controlled by its own transistor.

**TKIP** Temporal Key Integrity Protocol

## U

**URL** Uniform Resource Locator. A name used to describe the address of a specific resource on the internet.

**USB** Universal Serial Bus. A serial bus standard to interface devices.

## V

**VoIP** Voice over Internet Protocol. The routing of voice conversations over the Internet or through an IP-based network.

## W

**WEP** Wired Equivalent Privacy, a security protocol for wireless networks that encrypts transmitted data.

**WLAN** Wireless Local Area Network

**WPA** Wi-Fi Protected Access, wireless security with greater protection than WEP.

## Z

**ZRTP** ZRTP is a cryptographic key-agreement protocol to negotiate the keys to encrypt VoIP phone calls. ZRTP describes a method of Diffie-Hellman key agreement for Secure Real-time Transport Protocol (SRTP).

## Numerics

- 3.1 kHz Audio number, 47
- 501 phone number
  - data connections, 82
- 870, call, 47

## A

- active alarms
  - BGAN, 86
- adjust
  - backlight, 72
  - sound, 69
  - standby backlight, 72
  - volume during call, 52
- alarm
  - active BGAN, 86
  - alert BGAN, 85
- answer when lifted, 71
- audio
  - suppress, 69
- authentication, 49
- auto power off, 73
- automatic IP address, 67
- automatic secure, 48
- automatic shut down, 73

## B

- backlight, 72
  - adjust, 72
  - standby, adjust, 72
  - suppress, 69
- batter
  - remove, 103
- battery

- charging, 18
- charging interval, storage, 20, 102
- dispose of, 103
- leak, 102
- stand-by time, 4
- BGAN
  - call using, 46
  - enter PIN, 85
  - menu, 83
- BGAN critical alarms, 86
- BGAN software version, 84
- BGAN status information, 84
- BGAN terminal, 24
  - configuration, 48
  - setup, 24
- BGAN terminal type, 84

## C

- cable relief, 9
- call
  - +870, 47
  - encrypted, 47
  - ending or rejecting, 46
  - from BGAN terminal, 46
  - make, 25
  - making, 38
  - receiving, 40
  - secure, 47
  - transferring, 40
- call log, 93
  - add number to contacts, 57
  - delete a number, 58
  - delete all numbers, 58
  - manage, 57

- memory usage, 58
- call services, 70
- CE compliance, 117
  - wired handset, 117
  - wireless handset, 119
- change hands-free mode, 52
- charging
  - connector, 15
  - USB charger, 18
  - wireless handset, 18
- CNo, 84
- codec priority
  - SIP profile, 79
- compass safe distance
  - wired handset, 108
  - wireless handset, 112
- configuration
  - BGAN terminal, 48
- configure
  - web interface, 25
- confirm SAS, 49
- conformity
  - wired, 117
  - wireless, 119
- connect external power supply, 16
- connecting
  - BGAN terminal, 12
- connecting cradle
  - LAN cable, 9
- connecting the handset, 9
- connection, start
  - IP background, 82
  - IP streaming, 82
- connector
  - cradle, 8
- connectors, 8
- contact information, 101
- contacts, 59
  - add, 59, 92

- call, 59
- delete, 60, 92
- display, 59
- edit, 60, 92
- control functions
  - BGAN terminal, 2
- control keys, 27
- cradle
  - connector, 8
  - detection, 71
  - dimensions, 115
  - installing, 11
  - measures, 11
  - outline, 115
- critical alarm
  - display, 85

## D

- date and time setting, 74
- day/night mode, automatic, 72
- Declarations of Conformity
  - wired, 118
  - wireless, 122
- Default gateway
  - show, 61
- default settings, 75
- DHCP, 67
- diagnostics report, 99
- dialled number, 57
- dimensions
  - cradle, 115
  - handset, 109
- display
  - icons, 34
  - night colors, 53
  - overview, 32

- settings, 72
- disposal
  - battery, 103
  - IP Handset, 103
  - rules for, iii
- DNS
  - primary and secondary, enter, 68
- document number
  - this manual, i

## E

- encrypted call, 47
- encryption
  - protocol, 108
  - secure call, verify, 50
  - setup, 70
  - verification, 49
- external power supply, 15

## F

- factory default, 75
- fail
  - secure call, 51
- FCC compliance, 117
  - wired handset, 117
  - wireless handset, 119
- features, 5
- firmware
  - uploading, 96

## G

- gateway
  - enter, 68
- go secure, 48
- GPS position, 84

## H

- hand-held mode, 52
- handset, 24
  - connecting, 9
  - connecting to BGAN terminal, 12
  - dimensions, 109
  - features, 5
  - outline, 109
  - register, 22, 23
- handsets
  - setup further handsets, 23
- hands-free
  - change mode, 52
  - operation, 52
- headset, 55
- help, 99

## I

- icons in display, 34
- identification of the handset, 91
- import/export settings, 97
- installation
  - cradle, 11
- IP address
  - automatic, 67
  - DHCP, 67
  - show, 61, 89
  - static, 67
- IP background
  - start connection, 82
- IP Handset
  - getting to know, 2
  - setup, 24
  - switch off, 13

- switch on, 13
- IP mode, 67
- IP streaming
  - start connection, 82

## K

- key negotiation, secure call, 49
- keypad
  - alpha-numeric keys, 29
  - click, 69
  - control keys, 27
  - description, 26
  - locking, 53
  - shortcuts, 31
- keys
  - text and symbols, 29

## L

- LAN cable, 9
- leaking battery, 102
- local number, 24
  - BGAN terminal, 24
- locking the keypad, 53
- lowercase mode, 29

## M

- MAC address, 61
- make a call, 25
- manual
  - document number, i
- memory usage
  - call log, 58
- menu overview, 56
- menus

- main, 32
- microphone, muting, 53
- missed calls, 57
- mobile number, 47
- muting the microphone, 53

## N

- network information, 91
- network settings
  - wireless, 62
- night mode, 53
  - automatic switch to, 72
- noise cancellation, 70
- number mode, 29

## O

- outline
  - cradle, 115
  - handset, 109

## P

- password
  - SIP client, 79
- phone book, 59, 92
- Phone settings, 68
- physical address
  - IP Handset, 61
- PIN
  - BGAN, 85
  - wrong PIN, 23
- PIN status, 84
- PoE standard, 12
- port number, 78
- power
  - connect to cradle, 16

- off, 13
- off, automatic, 73
- on, 13
- on, off, 26
- stand by, 4

Power over Ethernet  
standard, 12

power supply, 15

PUK code, 23

## R

received calls, 57

register

- handset, 22, 23

remove battery, 103

reregister

- SIP server, 79

reset, 75

restore factory settings, 75

ringing tone, 69

router configuration, 48

RTP streaming, 47

## S

safety summary, iii

SAS, 49

SAS confirmation, 49

screensaver, 36, 72

secure call, 47

- automatic, 48, 70
- confirm, 49
- failed, 51
- how to start, 48
- setup, 48

- single call, 48
- select a SIP profile, 76
- serial number, 61
- set up, 24
  - IP Handset, 24
- Short Authentication String, 49
- shut down
  - automatic, 73
- signal strength, 84
- SIP client, 76
  - password, 79
  - user name, 79
- SIP fault, 106
- SIP profiles, 94
  - activating, 76
  - adding, 77, 95
  - codec priority, 79
  - deleting, 80, 95
  - editing, 80, 95
  - selecting, 76
- SIP requirements, 47
- SIP server, 77
  - name, 78
  - port number, 78
  - reregister, 79
  - STUN, 79
- SIP Service Provider
  - requirements, 47
- SIP telephony, 76
- software error, 106
- software upload, 96
- software version
  - BGAN terminal, 84
  - IP Handset, 61, 91
- sound

- adjust, 69
- specifications, 107
- SSID, 64
- standard voice number, 47
- standby backlight, 72
- stand-by time, 4
- start secure call, 48
- static IP address, 67
- Status, 84
- status, 91
- stealth mode
  - on, off, 69
  - quick setting, 54
  - setting up, 69
- streaming connection
  - start, 82
- STUN server
  - SIP server, 79
- Subnet mask address
  - show, 61
- support, 101
  - diagnostics report, 99
- switch off
  - IP Handset, 13
- switch on
  - IP Handset, 13

## T

- technical specifications, 107
- terminal type, BGAN, 84
- text mode, 29
- text, writing in display, 54
- time setting, 74
- tone volume, 69
- transfer a call, 40
- transparency, 72
- troubleshooting guide, 106
- typography used in this manual, vi

## U

- unlock, 23
- uploading firmware, 96
- uppercase mode, 29
- USB
  - charger, 18
  - charging connector, 15
- user interfaces, 37
- user name
  - SIP client, 79

## V

- verify secure call, 50
- VoIP protocol, 108
- volume
  - adjusting during call, 52
  - up or down, 28

## W

- web server
  - accessing, 89
  - browser settings, 87



- call log, 93
- contacts, 92
- enabling or disabling, 73
- Home, 91
- import/export settings, 97
- introduction, 87
- overview, 90
- SIP settings, 94
- using, 87
- wired handset
  - getting started, 7
- wireless
  - standard, 15
- wireless access point
  - connecting the IP Handset, 20
  - connection, 15
- wireless handset
  - getting started, 7
- Wireless network use
  - set country, 67
- WLAN
  - connecting, 62
  - editing profile, 64
  - standard, 15
- writing text in display, 54

## Z

- ZRTP protocol
  - secure call, 47





98-126059-G